

TECHNICAL SPECIFICATIONS

GENERAL

Code	Black	43901
	White	---
Name	MR-F 214	
Description	Flying Bar	
MAX n° of speaker	24	
Accessory combo	MR-F 214 - MR-J 214	

COMPATIBLE PRODUCTS

MYRA Series	214L
-------------	------

MECHANICAL SPECIFICATIONS

Material		Steel
Net dimensions - FRAME (WxHxD)	mm	890 x 152 x 520
	inch	35.03 x 5.98 x 20.47
Net weight - FRAME	kg	33
	lb	72.75
Net dimensions - FLYBAR (WxHxD)	mm	990 x 145 x 25
	inch	38.96 x 5.70 x 0.98
Net weight - FLYBAR	kg	13
	lb	28.66

DIMENSIONAL DRAWING

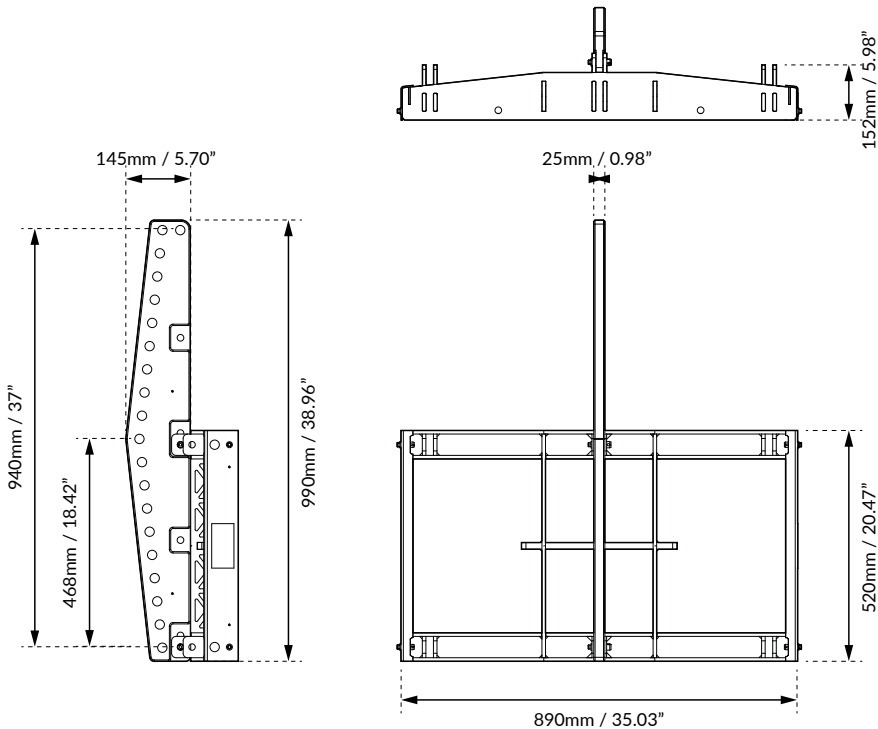

MR-F 214 CONFIGURATIONS

The MR-F 214 flying bar can be used for the installation of a line array consisting of up to 24 MYRA 214L modules.

⚠ WARNING | During installation, make sure that the system's supporting framework is included in the calculation of the total weight, along with the flying bar, hoist chain, motors, cables, and any additional weight.

⚠ WARNING | FBT also provides software to assist in calculating the safety factor of the weakest point in the suspension system according to the selected configuration.

⚠ WARNING | FBT accepts no responsibility for any damage to persons or property resulting from failure to comply with these instructions or from insufficient verification of the safety factor of all elements related to the system suspension.

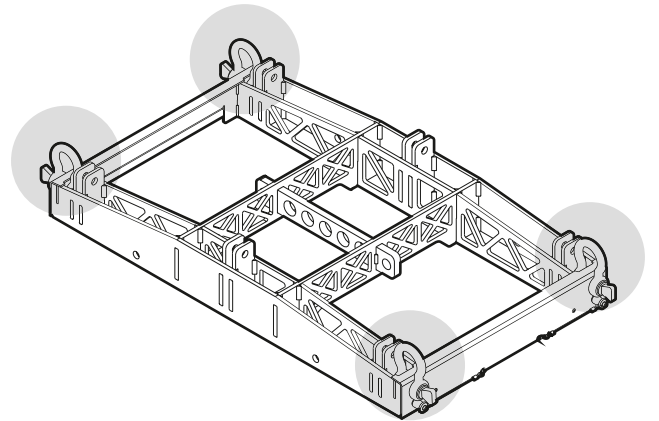

Use of the frame only, without the suspension bar and with four lifting points. Recommended for an array configuration of up to 24 MYRA 214L modules in fixed and permanent installations.

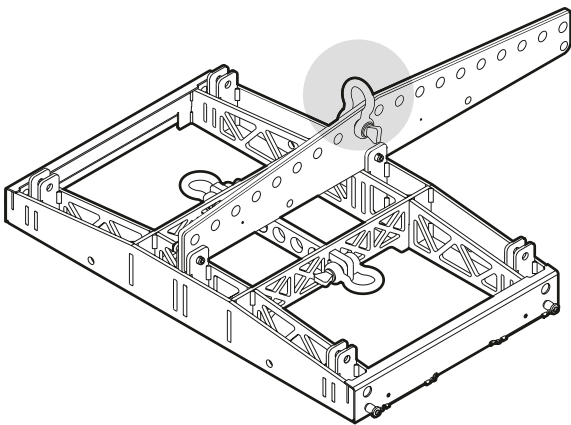

Use of the frame and suspension bar with a single central lifting point. Recommended for an array configuration of up to 16 MYRA 214L modules.

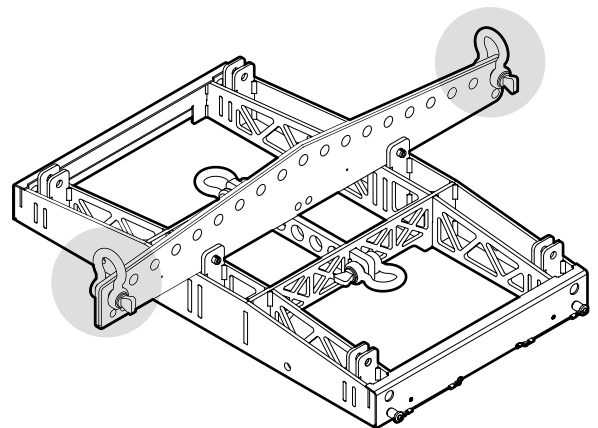

Use of the suspension bar in a central position with two lifting points; this configuration provides the best weight distribution. Recommended for an array configuration of 16 to 24 MYRA 214L modules.

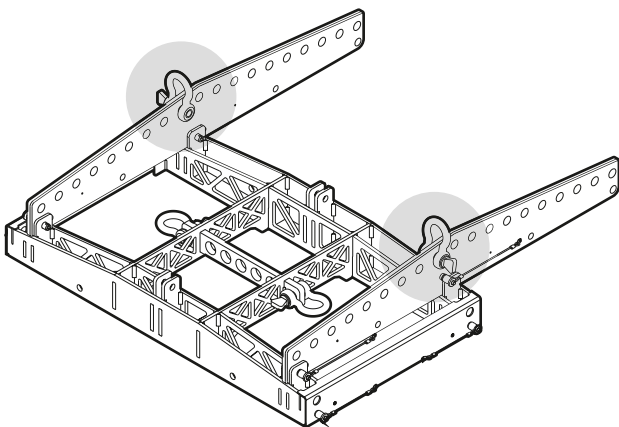

Using two side suspension bars and two lifting points. Recommended for an array configuration of 16 to 24 MYRA 214L modules.

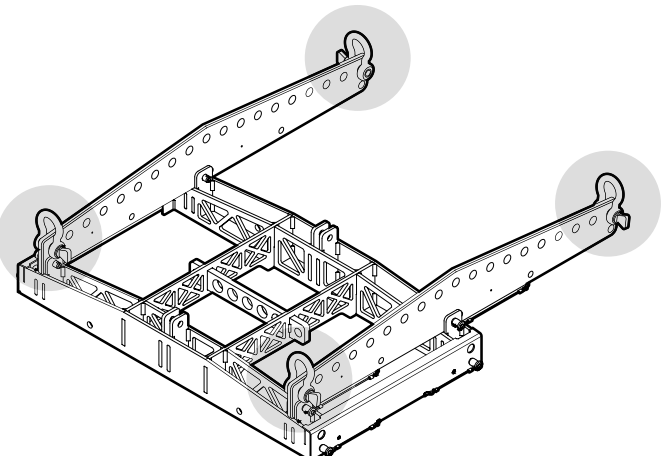

Using two side suspension bars and four lifting points. Recommended for an array configuration of 16 to 24 MYRA 214L modules.

WARNING



The installation of FBT acoustic speakers, using the suspension accessories described in this manual and the specific installation instructions, must be carried out exclusively by qualified personnel, in full compliance with the rules and safety standards in force in the country where the installation takes place. FBT suspension accessories are designed exclusively for use with FBT systems and must not be used in combination with any other speaker or device. Every element of the ceiling, wall, or other support where a FBT system is installed or suspended must be capable of safely supporting the load. All speakers installed in workplaces and/or entertainment venues must, in addition to the main suspension system, be equipped with an independent secondary safety system with adequate load capacity. For fixed installations, regular and specific inspections must always be planned and carried out to verify all components that ensure the long-term safety of the system.

- FBT speakers must be suspended only using original accessories.
- When selecting the installation location, suspension cables, and mounting supports, ensure that all components are capable of supporting the combined weight of the speaker and suspension accessories with an appropriate safety factor.
- For fixed installations, always schedule and perform regular inspections to verify all components that ensure the long-term safety of the system.
- Never suspend the speakers using the handles; the handles are designed for transporting the speaker, not for suspension.
- Never hang onto or cling to the speaker when it is suspended.

WARNING | When suspending FBT models, use only FBT mounting supports. The use of other mounting supports may cause dangerous instability, potentially resulting in harm to people or property.

WARNING | To prevent harm to people or property, it is essential to equip the system with the provided safety cables when the speaker is wall-mounted. Carefully select the installation area and ensure that the supporting structure is adequate to bear the weight of the speaker.

WARNING | FBT ELETTRONICA SpA is not responsible for any damage to persons or property resulting from failure to comply with these instructions or failure to verify the safety factor of all components involved in suspending the system.

SUSPENSION BAR AND FRAME ORIENTATION

There are two different ways to position the suspension bar on the frame of the array.

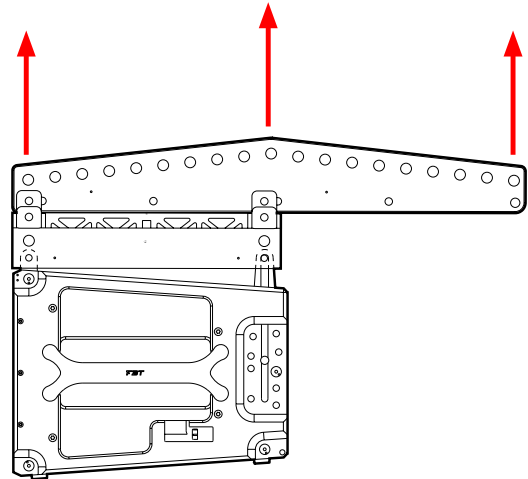

NORMAL

This is the standard attachment position for most arrays. It allows adjustment from a minimum to a maximum downward inclination.

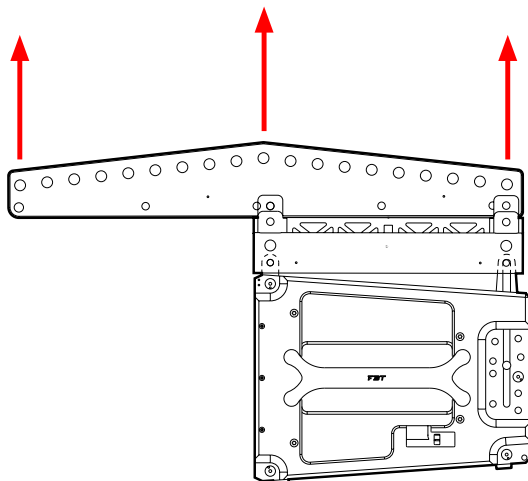

REVERSE

This attachment position can be used when a greater upward inclination is required, but only with a limited number of modules.

WARNING | All quick-release pins must always be inserted in their designated attachment points. Do not suspend the system if any pins are hanging loose.

MR-J 214 PULLBACK SUSPENSION BAR

The MR-J 214 is a suspension bar designed to provide pullback functionality for a MYRA 214L array. It can be attached to the bottom cabinet of an array and connected to a rear suspension point to allow for a greater downward tilt than is possible using the MR-F 214 flybar alone.

The suspension bar is attached to the rear of the last module at the bottom; the corresponding attachment points are marked both on the side label of the accessory and on the side of the cabinet (LINK with LINK / MR-J 214 with MR-J 214) (see fig.1). The primary role of the suspension bar is to serve as a pullback attachment at the bottom of an array, facilitating configurations that require a significant amount of downward tilt. In this setup, the MR-F 214 flybar is used at the top of the array as the primary suspension point, while the MR-J 214 is attached to the bottom and lifted by a second, rear motor point. The two motors are used together to achieve the desired array tilt angle.

Pullbacks are particularly useful when the center of gravity (CoG) of the array falls outside the footprint of the array frame, preventing the desired tilt from being achieved using the frame alone (Example 1). Using the suspension bar as a bottom frame helps shift the array's CoG between the two suspension points, enabling almost any downward angle to be achieved (Example 2).

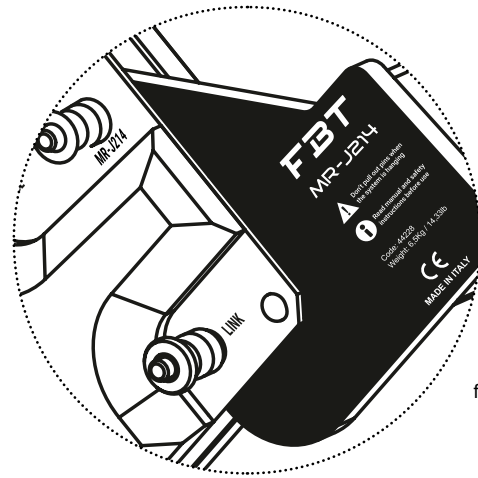
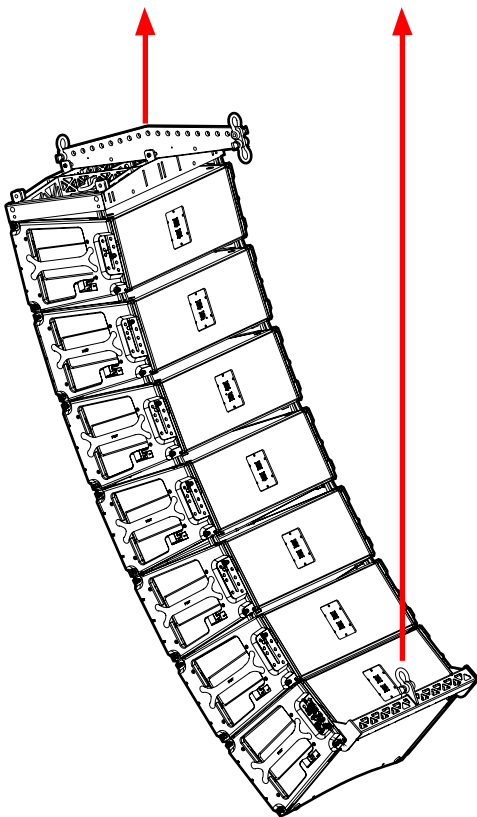
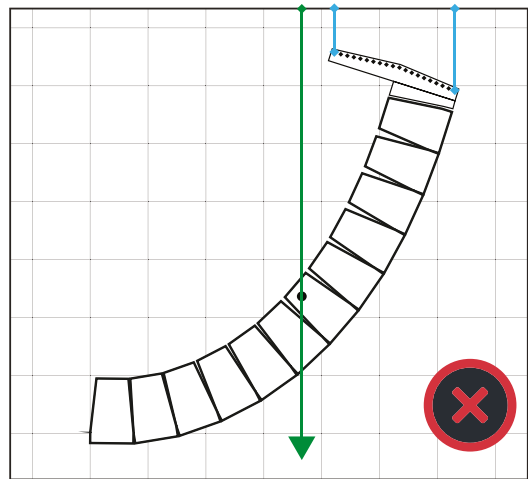

fig.1



EXAMPLE 1



● Center of gravity ● Suspension points

EXAMPLE 2

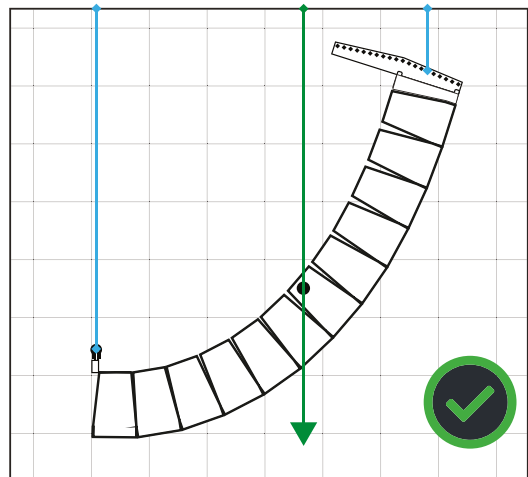

● Center of gravity ● Suspension points