

# 4-Channel Processed Digital Network Amplifier

## MAIN APPLICATIONS

Permanent installations in:

- Small Theatres, Auditoriums, Conference Rooms, Piano Bar, DJ
- Fixed installations in live cubs
- Pubs, Gyms



## MAIN FEATURES

- 4 x 150W on 4 to 16Ohm Load
- 2 x 300W (BTL mode) on 70V / 100V line
- 70Vp (SE) and 140Vp (BTL) maximum voltage output
- 1U rack mount chassis
- Multi-channel power amp with direct drive both high-impedance (70V/100V line) or low-impedance (4Ω/8Ω/16Ohm)
- Single ended and Bridge mode operation
- Full asymmetric loading allows power to be distributed per channel as needs dictate
- Network interface TCP / IP - AES70 compatible combine with INFINITO software suite for PC allows control and monitoring of multiple amplifiers
- EtherCon RJ45 input and output for daisy-chain
- OLED DISPLAY and ENCODER with PUSH for easy onboard control
- 4 channels DANTE audio streaming receiver with 24bit at 48-96KHz on TCP / IP network
- Switch mode power supply with universal voltage and power factor correction (PFC) – Efficiently manages the current drawn from the AC mains, ensuring harmonic control and decreasing the amount of current draw while allowing the amplifier to drive loudspeakers to maximum output longer without power fluctuation. PFC provides superior transient response and functions at peak burst power much longer than conventional Class-D amplifier designs to satisfy the requirements of even the most demanding program material.
- Auto-Standby/Auto-Wake function – When enabled, this function automatically enters/exits Standby Mode, allowing the system to consume less power.
- Complete set of powerful, intelligent protection features for more reliable operation.
- 8 channel GPIO software configurable as Input or Output for easy interface with external device
- Screw Euroblock input / output connectors

## DESCRIPTION

The MIURA 604I is a professional multi-channel power amplifier designed for installation and fixed audio applications. It delivers 4×150 W on 4 to 16Ohm loads, or 2×300 W (BTL mode) on 70/100 lines, providing maximum flexibility for both low- and high-impedance systems. The maximum output voltage is 70Vp (SE) and 140Vp (BTL). The amplifier is housed in a 1U rack-mount chassis, compact and robust, ideal for professional installations. The MIURA 604I operates in Single Ended and Bridge modes and features full asymmetric loading, allowing power to be distributed per channel as needs dictate. It is capable of direct drive of both high-impedance (70/100V lines) and low-impedance (4/8/16Ohm) loads, offering high efficiency and excellent audio performance. The unit includes a TCP/IP network interface – AES70 compatible, combined with the INFINITO software suite for PC, which allows the control and monitoring of multiple amplifiers within the same network. EtherCon RJ45 input and output connectors are provided for daisy-chain connection, and a 4-channel DANTE audio streaming receiver is integrated, supporting 24-bit audio at 48–96kHz over the TCP/IP network.

The front panel features an OLED display and push-button encoder for easy onboard control. Power is supplied by a switch-mode power supply (SMPS) with universal mains voltage and Power Factor Correction (PFC). This design efficiently manages the current drawn from the AC mains, ensuring harmonic control and reducing power consumption while allowing the amplifier to drive loudspeakers to maximum output for longer periods without power fluctuation. The PFC provides superior transient response and enables operation at peak burst power for significantly longer durations than conventional Class-D amplifier designs, satisfying the requirements of even the most demanding program material. The Auto-Standby/Auto-Wake function, when enabled, automatically enters or exits standby mode, allowing the system to consume less power during idle conditions. A complete set of powerful and intelligent protection features ensures reliable operation under all conditions. The amplifier also provides 8-channel GPIO, software-configurable as Input or Output, for easy interface with external devices, and screw Euroblock input/output connectors for secure and efficient wiring.

**TECHNICAL SPECIFICATIONS**

Code		45512
Channels		4 LoZ / 2 HiZ
Output power LoZ (4/8/16 Ohm) single channel driven	W - Ohm	250 - 4
		250 - 8
		150 - 16
Output power LoZ (4/8/16 Ohm) all channels driven	W	4 x 150
Output power HiZ (70/100V)	W	2 x 300
Max output voltage unloaded	Vp / Vp	70 (LoZ) / 140 (HiZ)
Amplifier tipology		Class D - PWM modulator with ultra low distortion
S/N ratio	dB	>106 (A-weighted)
THD+N		<0.05% (20Hz - 20KHz, 8Ohm, 3dB below rated pwr)
Frequency response	Hz	20 - 20k (-0.5dB , 3dB below rated power)
Protection		Short Circuit, DC, Undervoltage, Temperature, Overload
Cooling		Variable speed fan
Power supply		Regulated switch mode with Power Factor Correction (PFC) and ST-BY feature
Operating voltage		Universal main voltage 100 - 240 Vac@ 50/60Hz
Power consumption   St-by - Idle - 1/8 PWR	W	670   13 - 25 - 130
Operating temperature		0 - 40°C
Net dimensions (WxHxD)	mm	1U Rack Mount   482 x 44 x 485
	inch	1U Rack Mount   18.97 x 1.73 x 19.09
Net weight	kg	4.50
	lb	9.92

**DIMENSIONAL DRAWINGS**

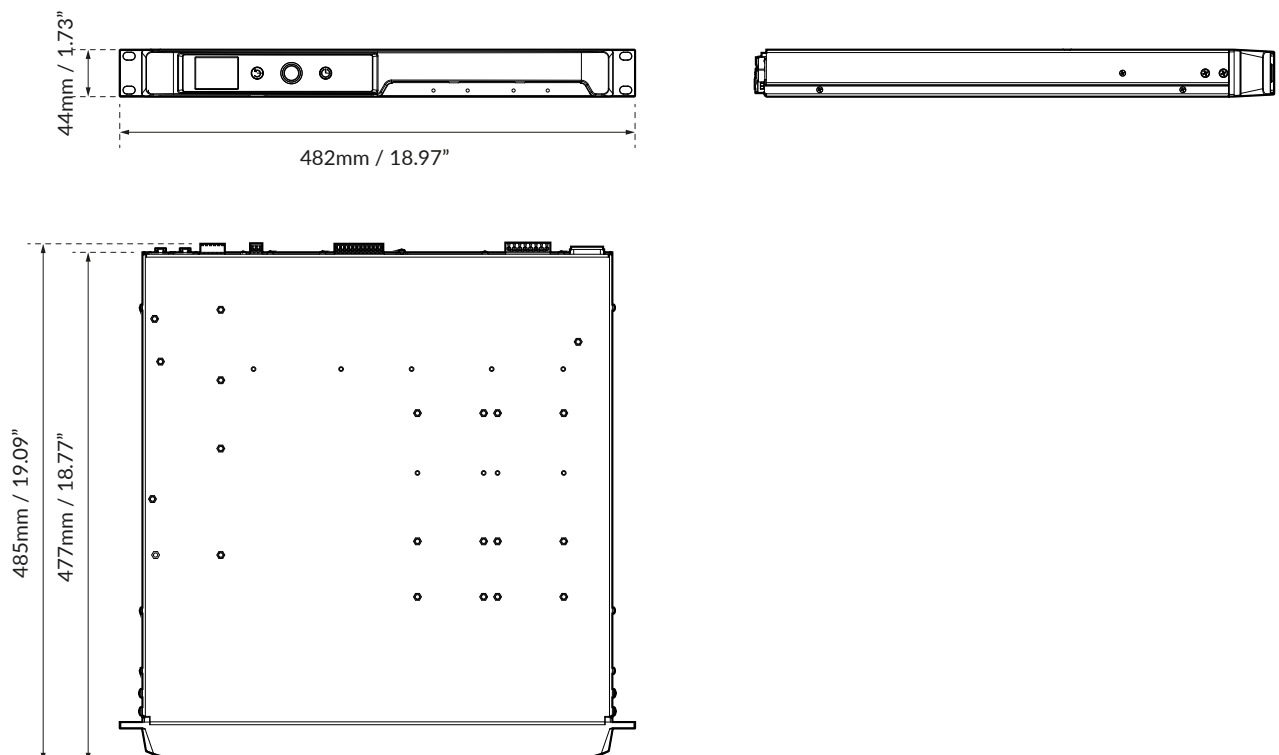

## CONTROL PANEL

## FRONT PANEL

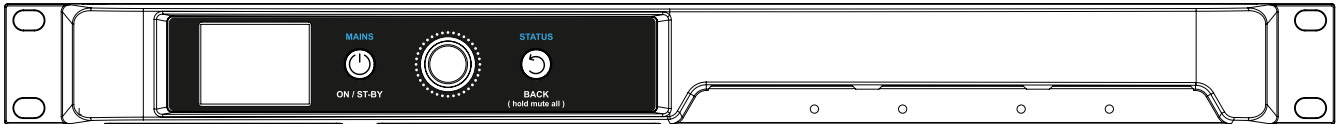

## REAR PANEL

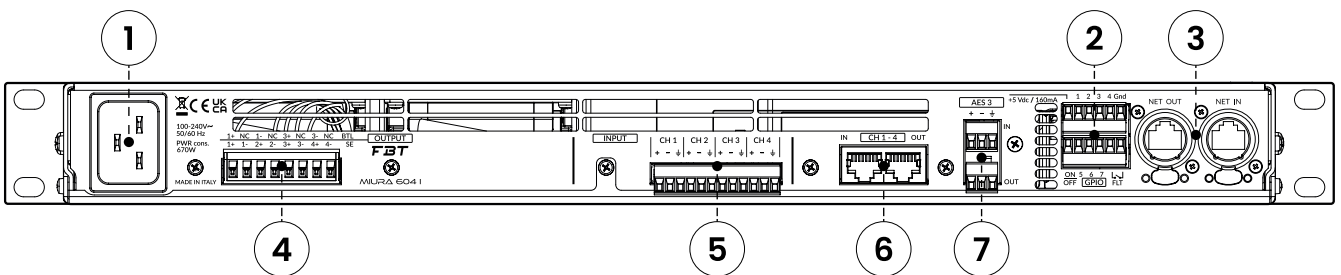

## INDICATORS

1. IEC 20A power connector
2. Euroblock for GPIO and fault relay configuration
3. EtherCON ports for network control / Dante
4. Euroblock for amplifier output channels (1-4)
5. Euroblock for balanced analog input channels (1-4)
6. RJ45 output for relaying balanced analog channels (1-4)
7. Euroblock for AES3 digital audio I/O