

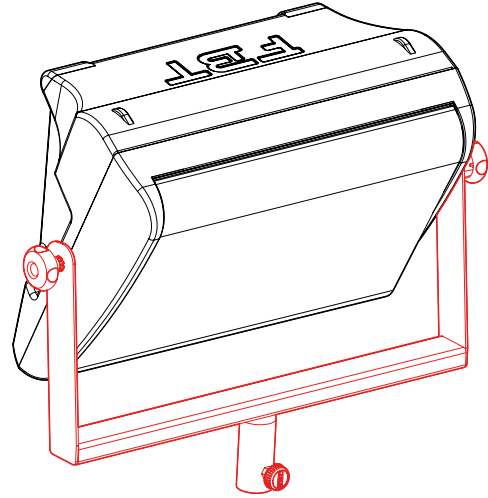

# SM-S 12M | Stand Adapter

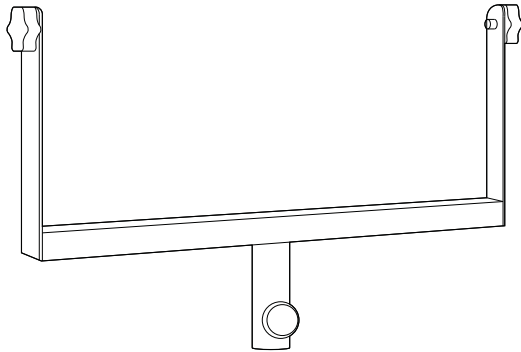

## TECHNICAL SPECIFICATIONS

### GENERAL

Code	Black	37099
	White	---
Name		SM-S 12M
Description		Stand Adapter
MAX n° of speaker		1

### COMPATIBLE PRODUCTS

STAGEMAXX		12MA
-----------	--	------

### MECHANICAL SPECIFICATIONS

Material		Steel
Net dimensions (WxHxD)	mm	575 x 262 x 50
	inch	22.63 x 10.31 x 1.96
Transport dimensions (WxHxD)	mm	610 x 75 x 410
	inch	24.02 x 2.95 x 16.14
Net weight	kg	2.80
	lb	6.17
Transport weight	kg	3.50
	lb	7.71

## DIMENSIONAL DRAWING

