

ABS Weather-proof Horn Speaker

MAIN FEATURES

- 2-way horn speaker system
- 6" LF woofer and 1" HF driver
- Extended frequency response: 90Hz - 20kHz
- 70 / 100V multi transformer taps (50/25/12.5/9/4.5/3.5W)
- Stainless steel bracket
- Rugged ABS cabinet
- Waterproof termination junction box

DESCRIPTION

Both the two MSH50T and HS50T sound projectors feature horn design, rugged construction material, waterproof grade, high sensitivity and narrow sound dispersion overall the speech spectrum. The 50W 2-way MHS50T model provides extended frequency response suitable for musical and voice applications, indoor and outdoor, such as warehouse, parking areas and swimming pools.

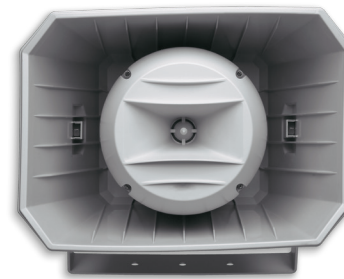

TECHNICAL SPECIFICATIONS

GENERAL

Code	White	29431
Configuration	way	2
Low frequency woofer	inch	6
High frequency driver	inch	1

ACOUSTIC SPECIFICATIONS

Frequency response	Hz	90 - 20k
Sensitivity	dB	99 ± 3
Line input	V	100

AMPLIFIER

Power handling	W	50
----------------	---	----

MECHANICAL SPECIFICATIONS

Material	Cabinet	ABS
	Grille	Steel
Net dimensions (WxHxD)	mm	362 x 315 x 300
	inch	14.52 x 12.4 x 11.81
Net weight	kg	3.80
	lb	8.37

DIMENSIONAL DRAWING

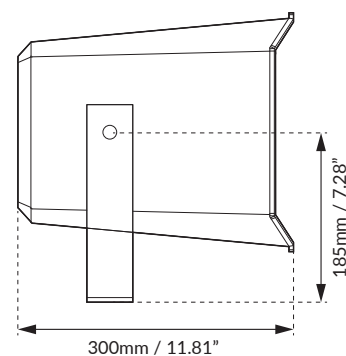
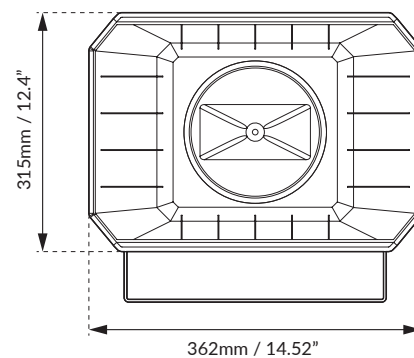

FREQUENCY RESPONSE DIAGRAMS

