

Horn Speaker

DESCRIPTION

MSH 15HF/EN horn speaker are fitted with fireproof cable according to UNI 9795 2010 (length 80cm). The fixing system makes mounting easy and enables the speaker unit to be turned in the best direction. These speaker units have been developed specifically for use in emergency and evacuation systems. These horns are two-way speaker units featuring high efficiency, an extensive response range and good power resistance. The design and materials used enable it to be employed for outdoor applications up to class of protection IP44 at the most. The special shape of these speakers gives rise to practically constant and controlled coverage of the audio spectrum reproduced, with particularly high sensitivity.

DIAGRAMS

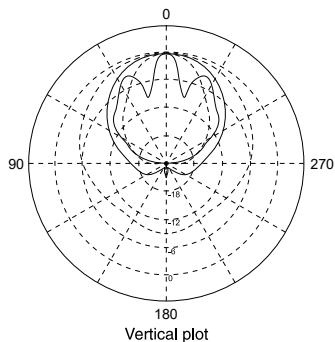
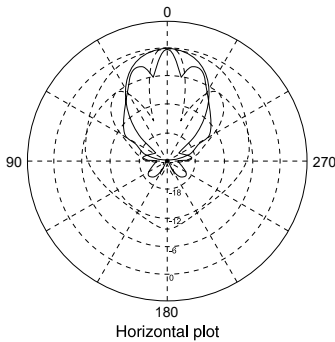
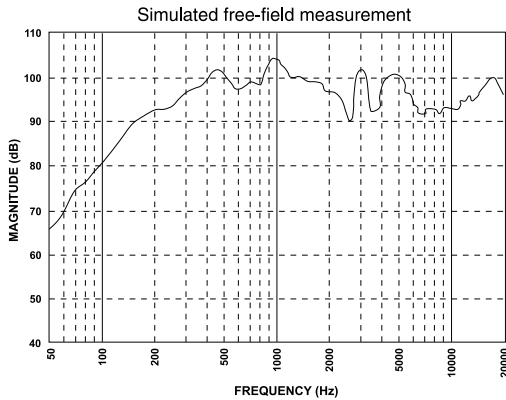

EN 54-24:2008

EN 54-24:2008
Cert. Nr. 0068-CPR-059/2016

Declaration of Performance (DoP)
available on the website: www.fbt.it

TECHNICAL SPECIFICATIONS

Code		40952
Low frequency woofer	inch	6.5
High frequency driver	inch	1 - dome
Rated power	W (V)	15 (100)
Nominal impedance	Ohm	16 / 666 / 1250 / 2500
Selectable power	W	15 / 8 / 4
Sensitivity (@1W/1m)	dB	98
MAX SPL (@15W/1m)	dB	110
Frequency response	Hz	160 - 20k
Horizontal angle of dispersion (-6dB)	(500Hz)	160°
	(1kHz)	70°
	(2kHz)	30°
	(4kHz)	60°
Vertical angle of dispersion (-6dB)	(500Hz)	200°
	(1kHz)	100°
	(2kHz)	60°
	(4kHz)	25°
Net dimensions (WxHxD)	mm	355 x 240 x 315
	inch	14 x 9.44 x 12.4
Net weight	kg	3.95
	lb	8.70