

APPLICATIONS

- Live Sound Reinforcement Floor Monitor
- Touring Systems, Clubs, Auditoriums, Theatres
- Houses of worship, D.J. Booth Monitor

FEATURES

- 0,59" baltic birch plywood cabinet, internally braced to prevent undesired resonance and vibrations
- 8" B&C woofer with 2" voice coil
- B&C HF compression driver with 1.4" voice coil and 1" exit
- Input panel with 2 x Neutrik speakon NL4 jacks
- Wall, ceiling, cluster, speaker stands. Optional accessories required
- Four M6 fly omni-mount anchoring points
- High SPL capability: 123dB
- Completely Manufactured in Italy



PRODUCT DESCRIPTION

The FBT VERVE 8M passive speaker feature Baltic birch plywood construction, covered in a scratch & scuff resistant black finish. The FBT VERVE 8M is a two way coaxial design incorporating a 8" B&C woofer with 2" voice coil, B&C HF compression driver with 1,4" voice coil and 1" exit coaxially mounted. The FBT VERVE 8M floor monitors dispersion factor is 100° H x 100° V. With a frequency range of 75Hz-18kHz the FBT VERVE 8M provides hi fidelity sound for both speech and music applications with a maximum SPL of 123dB. A front face steel grille protects the woofer from external damage. Passive crossover filter featuring "soft trip" circuitry to ensure full protection of the LF woofer and HF driver. The four M6 omni-mount fly points built into the cabinet with the optional accessories allow the FBT VERVE 8M speaker to be surface mounted on walls or ceilings.

ELECTRICAL PERFORMANCE

System Type:	2 way coaxial
Recommended Amplifier	250W RMS
Long Term Applicable Power (AES)	125W
Short Term Applicable Power (IEC 268-5)	500W
Nominal Impedance	8 Ohm
Frequency Response @ -6dB	75Hz - 18kHz
Sensitivity @ 1W, 1m	95dB
Maximum SPL (continuous/peak)*	119dB / 123dB
Dispersion	100°H x 100°V
Crossover Frequency	2,2 kHz

PHYSICAL

Low Frequency Woofer	8" / 2" Coil
High Frequency Driver	1" / 1,4" Coil
Input Connectors	2 x Speakon NL4
Net Dimensions (WxHxD)	10,6" x 14,6" x 10,5"
Shipping Dimensions (WxHxD)	13,6" x 17,5" x 13,6"
Net Weight	19,8 lbs
Shipping Weight	24,2 lbs
Enclosure Material	0.59" Baltic birch plywood
Grille	Steel with powder coat black paint finish

* CONT. SPL: free space, based on recommended amp rating and LF transducer average sensitivity data, 125mS time average
PEAK SPL: free space, based on short term applicable power rating and system peak sensitivity, 10mS time average

DIAGRAMS

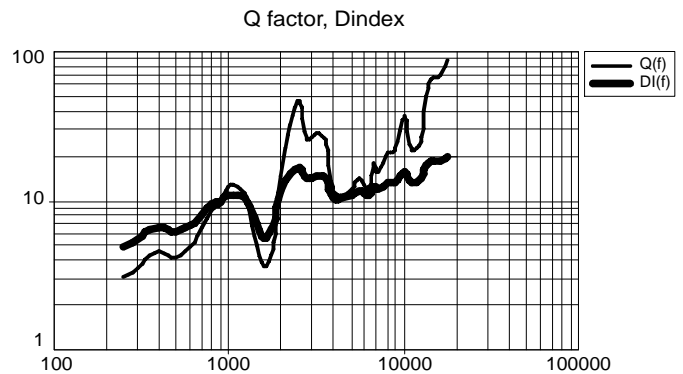
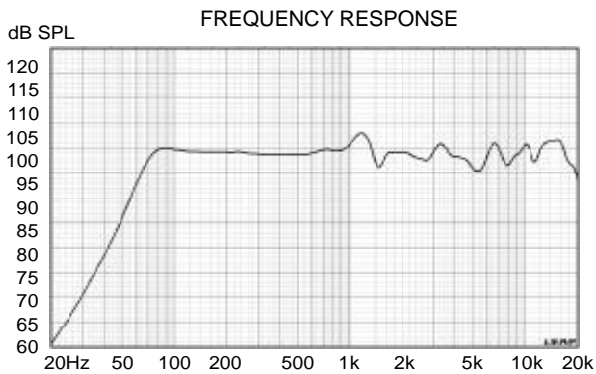
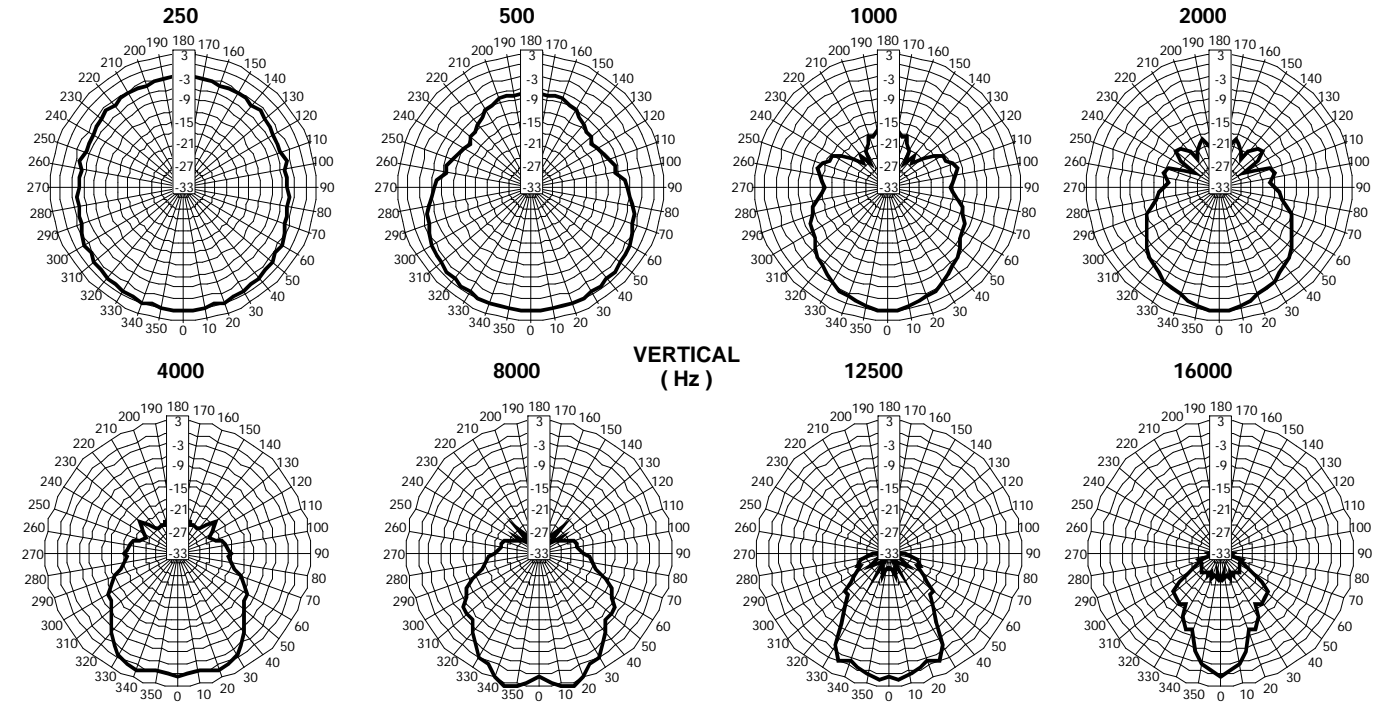
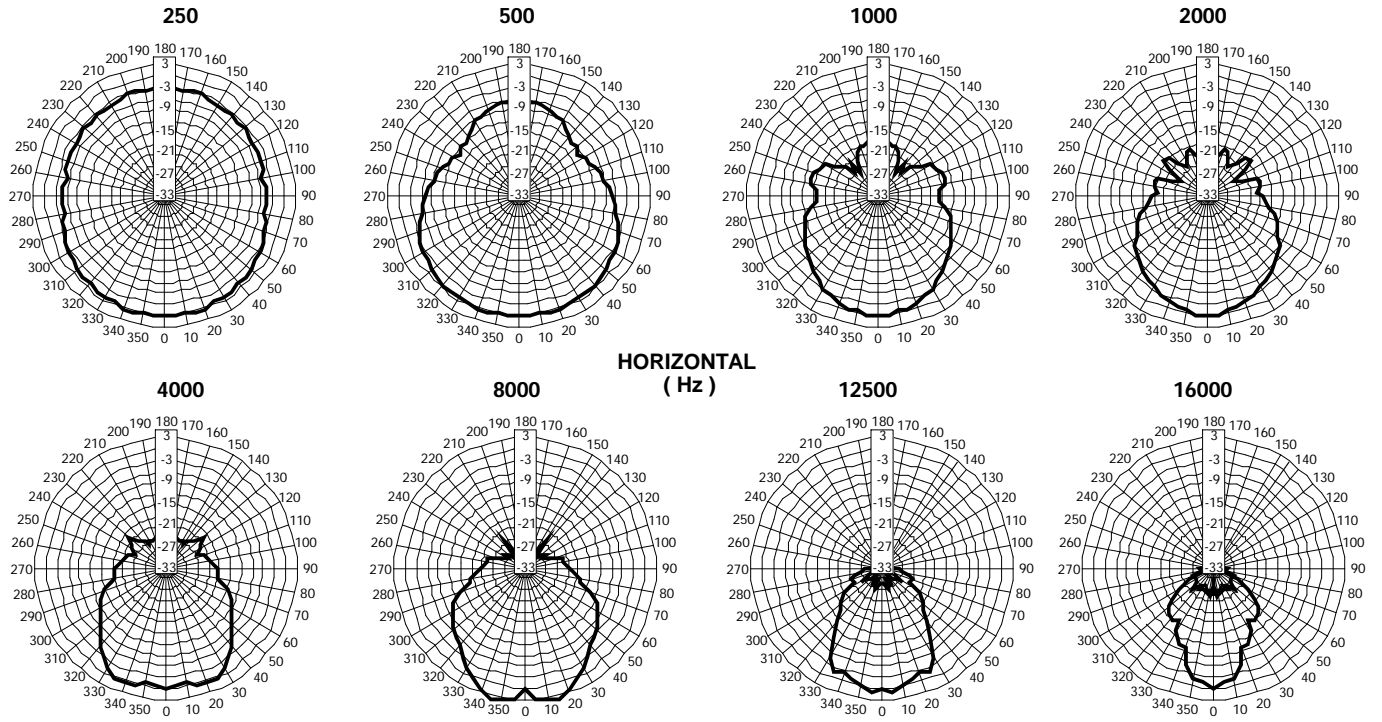

BLOCK DIAGRAM

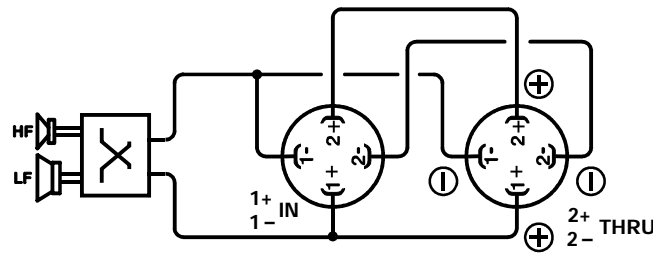

INPUT CONNECTORS

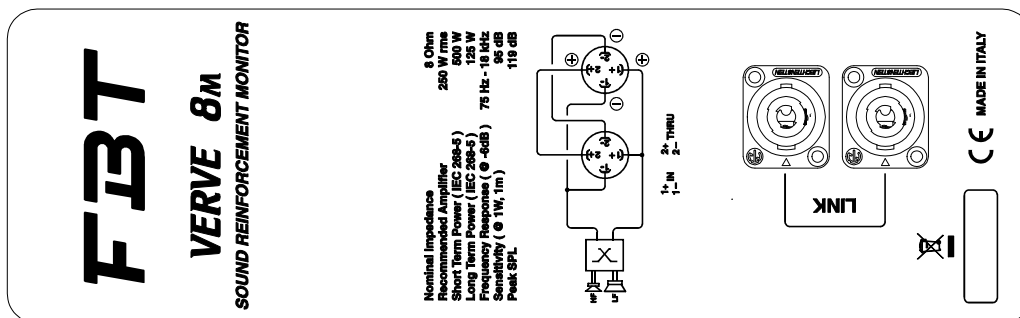

DIMENSION DRAWING

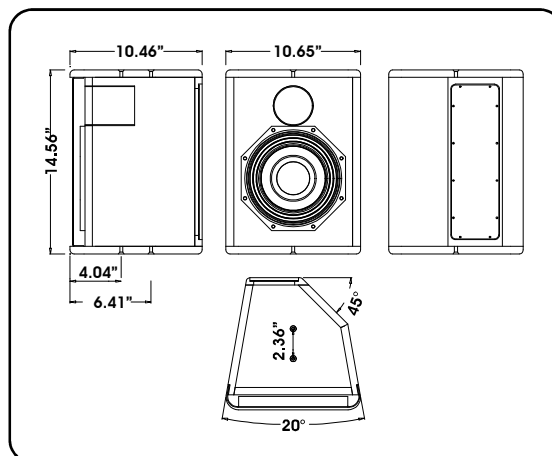

ACCESSORIES



BOX 119

Directional wall mount



BOX 121

Adjust. Stand adapter
2xM6
ø 35mm (1,38")



BOX 118

Stand adapter
2xM6
ø 35mm (1,38")



BOX 122

Adjust. truss clamp
2xM6



BOX 113

Mount for horizontal wall installation

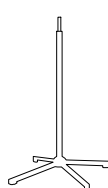

SS2
Standard speaker floor stand

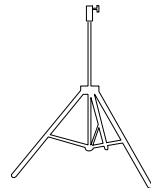

BOX 32BK
Adjustable aluminium floor stand, damped safety mechanism

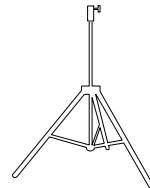

BOX 22BK
Adjustable aluminium floor stand, ø1.38" with ø1"adapter



BOX 52BK
Adjustable for sub-satellite speaker connection, with safety locking device

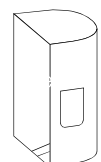

V 53
Nylon case