

APPLICATIONS

- Live Sound P.A. System or Live Sound Monitor, D.J. System
- School & Corporate Audio Visual Sound Reinforcement
- Background Music/Announcement: Restaurants, Pubs
- Transportation Terminals, Clubs, Auditoriums, Theatres
- Gyms, Houses of Worship

FEATURES

- 0,59" baltic birch plywood cabinet, internally braced to prevent undesired resonance and vibrations
- 10" B&C custom neodymium woofer
- B&C HF compression driver with 1.4" voice coil and 1" exit
- 80° x 50° constant directivity rotatable horn
- Control panel with ground-lift, XLR input & output, 2-band EQ, signal/limiter/thermal led indicator, volume control.
- Wall, ceiling, cluster, speaker stands. Optional accessories required
- Six M10 fly points
- Metal carrying handle
- High SPL capability: 128dB
- Completely Manufactured in Italy



PRODUCT DESCRIPTION

The FBT VERVE10A bi-amplified speaker feature 0.59" Baltic birch plywood construction, covered in a scratch & scuff resistant black finish. The FBT VERVE 10A is a two way design incorporating a 10" B&C custom neodymium woofer with 2" voice coil, 1" B&C compression driver with 1.4" voice coil coupled to a rotatable 80° H x 50° V horn. Thanks to the rotatable HF horns it is possible to create horizontal arrays of 2 enclosures for a total coverage of 80°. With a frequency range of 62Hz-20kHz the FBT VERVE 10A provides hi fidelity sound for both speech and music applications with a maximum SPL of 128dB. The bi-amplified FBT VERVE 10A features a 300W RMS class "G" low frequency amp and a 100W RMS class "G" high frequency amp. The control panel features a master volume control, 2-band EQ with ±15dB of cut-boost LF and ±15dB of cut-boost HF, XLR input & output, ground lift switch and signal/limiter/thermal led indicator. A front face steel grille protects the woofer from external damage. The six M10 fly points built into the cabinet along with the optional BOX 114 or BOX 120 mounting brackets allow the FBT VERVE 10A speakers to be surface mounted on walls or ceilings. A standard 1,38" speaker stand socket allows the FBT VERVE 10A to be mounted on speaker stands.

ELECTRICAL PERFORMANCE

System Type:	2 Way
Internal Amplifier *	cont.: 250W+100W RMS max.: 300W+100W RMS max. peak: 600W+200W RMS
Low Frequency Woofer	10" / 2" coil
High Frequency Driver	1" / 1.4" coil
Input Impedance	22 kOhm
Frequency Response @ -6dB	62Hz - 20kHz
Input Sensitivity	0dBu line
Maximum SPL (continuous/peak) * *	121dB / 128dB
Dispersion	80°H x 50°V rotatable
Crossover Frequency	2 kHz
AC Power Requirement (continuous/peak)	280/650VA

PHYSICAL

Input Connectors	XLR with loop
Net Dimensions (WxHxD)	12,9" x 21,6" x 12,4"
Shipping Dimensions (WxHxD)	15,9" x 25" x 15,3"
Net Weight	39,68 lbs
Shipping Weight	43,21 lbs
Enclosure Material	0.59" Baltic birch plywood
Grille	Steel with powder coat black paint finish
Power Cord	16,4"

* CONT. : 500ms burst, rms power on nominal speaker impedance
 MAX: 2ms burst, rms power on nominal speaker impedance
 MAX PEAK: based on max peak output voltage and nominal speaker impedance

** CONT. SPL: free space, based on continuous power amp rating and LF transducer average sensitivity data, 125ms time average
 PEAK SPL: free space, based on max. peak power amp rating and system peak sensitivity, 10ms time average

DIAGRAMS

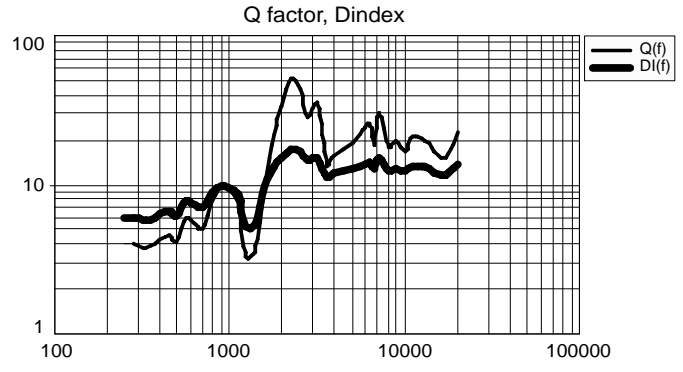
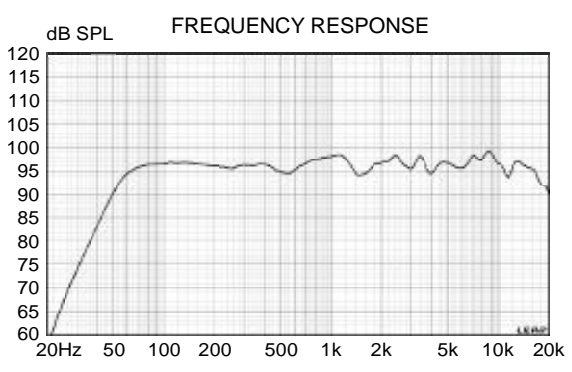
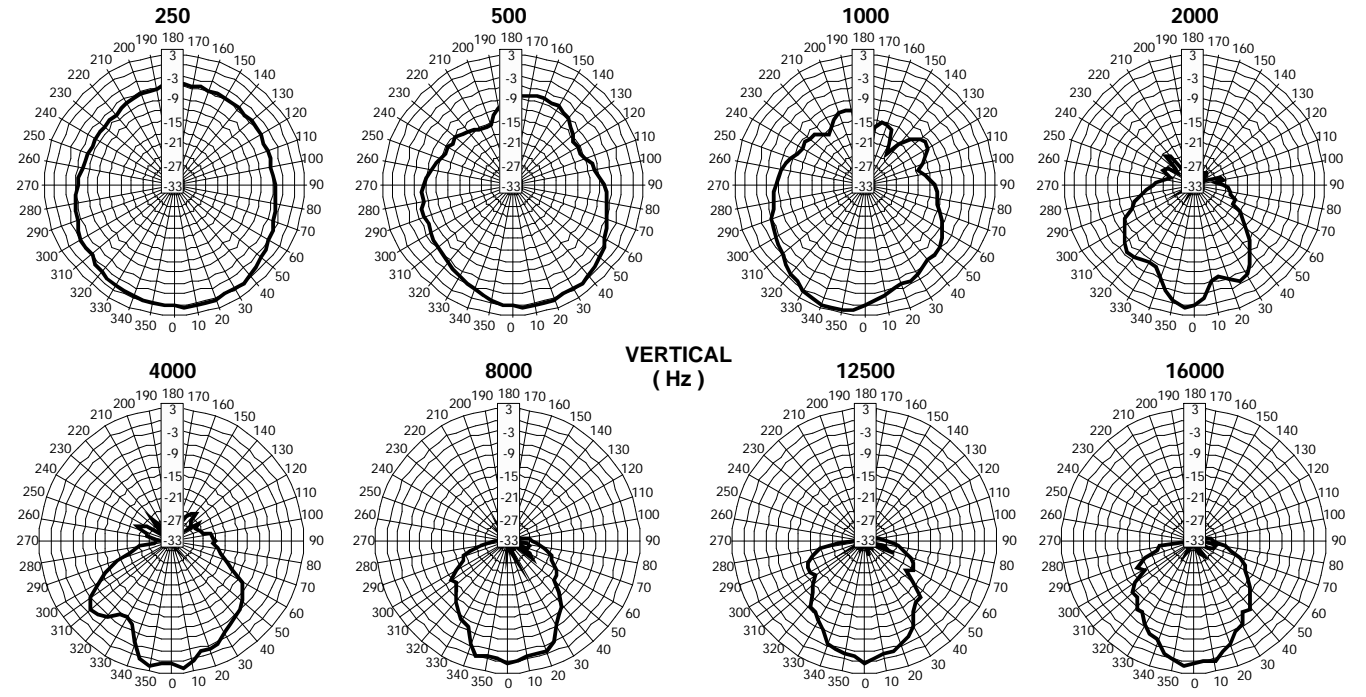
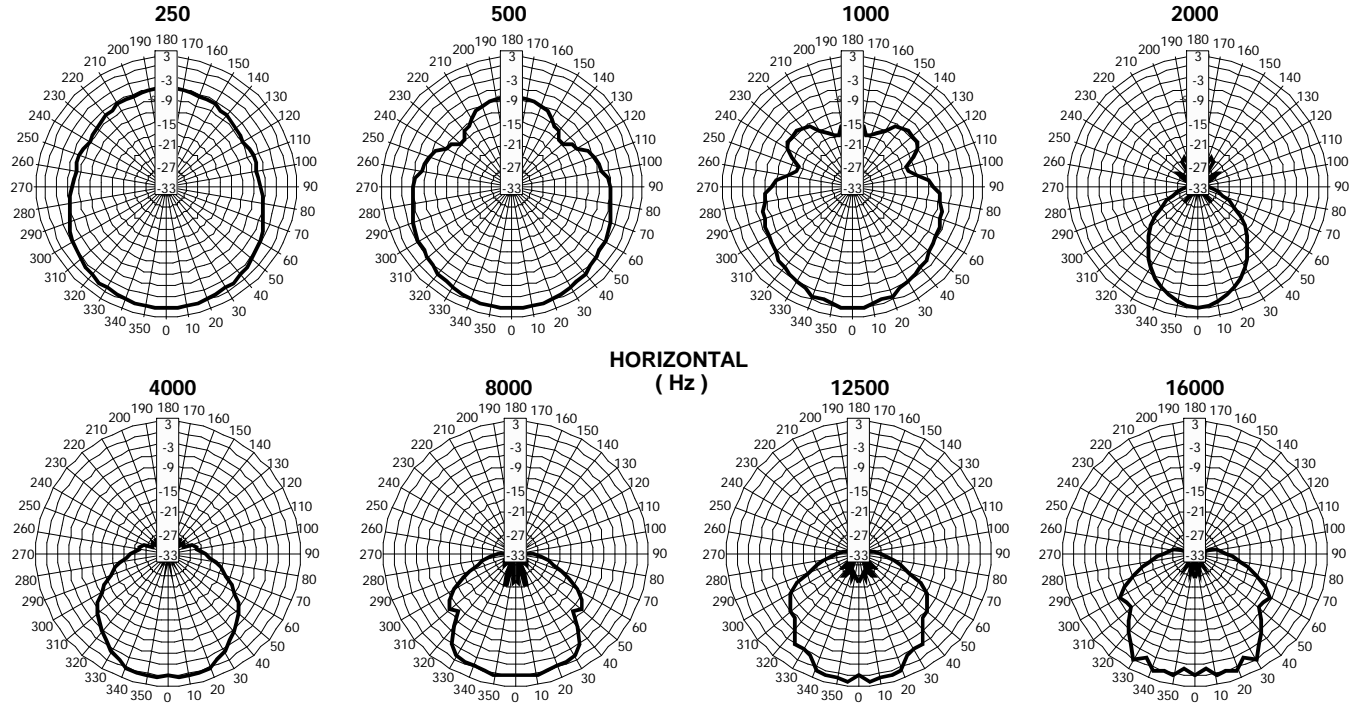

CONTROL PANEL

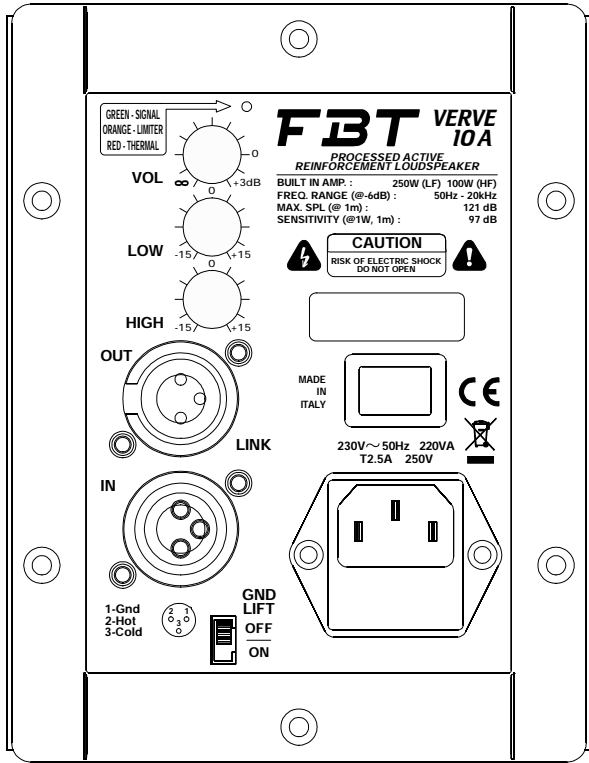

DIMENSION DRAWING

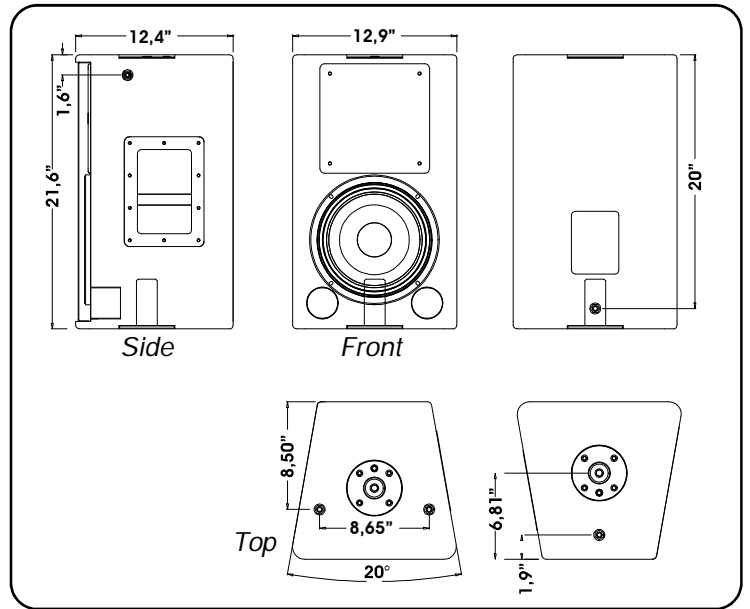

ACCESSORIES



BOX 120
Directional wall
mount

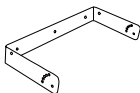

BOX 114
Mount for
horizontal
wall installation

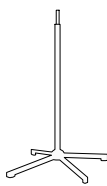

SS2
Standard speaker
floor stand

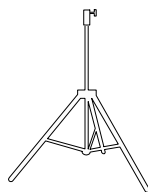

BOX 32BK
Adjustable aluminium
floor stand, damped
safety mechanism

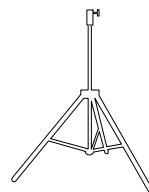

BOX 22BK
Adjustable aluminium
floor stand, $\phi 1.38''$
with $\phi 1''$ adapter

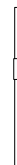

BOX 52BK
Adjustable for
sub-satellite
speaker connection,
with safety locking
device

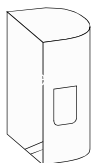

V 46
Nylon case