

APPLICATIONS

- Live Sound P.A. System or Live Sound Monitor, D.J. System
- School & Corporate Audio Visual Sound Reinforcement
- Background Music/Announcement: Restaurants, Pubs
- Transportation Terminals, Clubs, Auditoriums, Theatres
- Gyms, Houses of Worship

FEATURES

- 0,59" Baltic birch plywood cabinet, internally braced to prevent undesired resonance and vibrations
- 10" B&C custom neodymium woofer
- B&C HF compression driver with 1.4" voice coil and 1" exit
- 80° x 50° constant directivity rotatable horn
- Input panel with 2 x Neutrik speakon NL4 jacks
- Wall, ceiling, cluster, speaker stands. Optional accessories required
- Metal carrying handle
- Six M10 fly points
- High SPL capability: 124dB
- Completely Manufactured in Italy



PRODUCT DESCRIPTION

The FBT VERVE10 passive speaker feature 0.59" Baltic birch plywood construction, covered in a scratch & scuff resistant black finish. The FBT VERVE 10 is a two way design incorporating a 10" B&C custom neodymium woofer with 2" voice coil, 1" B&C compression driver with 1.4" voice coil coupled to a rotatable 80° H x 50° V horn. Thanks to the rotatable HF horns it is possible to create horizontal arrays of 2 enclosures for a total coverage of 80° . With a frequency range of 50Hz-18kHz the FBT VERVE 10 provides hi fidelity sound for both speech and music applications with a maximum SPL of 124dB. A front face steel grille protects the woofer from external damage. The passive crossover filter featuring "soft trip" circuitry to ensure full protection of the LF woofer and HF driver. The rear panel provides two NL4 Neutrik Speakon female connectors. The six M10 fly points built into the cabinet along with the optional BOX 114 or BOX 120 mounting brackets allow the FBT VERVE 10 speakers to be surface mounted on walls or ceilings. A standard 1,38" speaker stand socket allows the FBT VERVE 10 to be mounted on speaker stands.

ELECTRICAL PERFORMANCE

System Type:	2 Way
Recommended Amplifier	250W RMS
Long Term Applicable Power (AES)	125W
Short Term Applicable Power (IEC 268-5)	500W
Nominal Impedance	8 Ohm
Frequency Response @ -6dB	50Hz - 18kHz
Sensitivity @ 1W, 1m	97dB
Maximum SPL (continuous/peak)*	121dB / 124dB
Dispersion	80°H x 50°V rotatable
Crossover Frequency	2,2 kHz

PHYSICAL

Low Frequency Woofer	1x10" / 2" Coil
High Frequency Driver	1" / 1,4" Coil
Input Connectors	2 x Speakon NL4
Net Dimensions (WxHxD)	12,9" x 21,6" x 12,4"
Shipping Dimensions (WxHxD)	15,9" x 25" x 15,3"
Net Weight	30,8 lbs
Shipping Weight	34,4 lbs
Enclosure Material	0.59" baltic birch plywood
Grille	Steel with powder coat black paint finish

* CONT. SPL: free space, based on recommended amp rating and LF transducer average sensitivity data, 125mS time average
PEAK SPL: free space, based on short term applicable power rating and system peak sensitivity, 10mS time average

DIAGRAMS

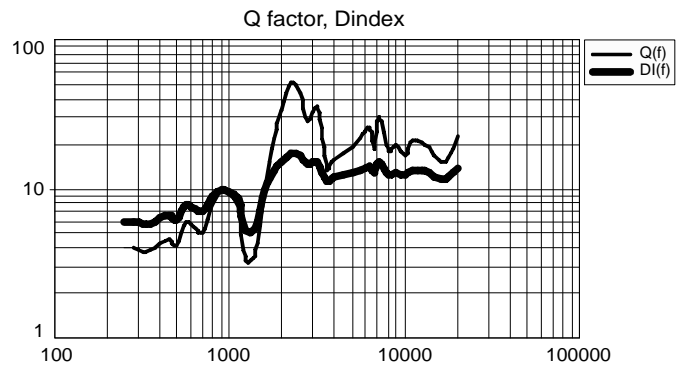
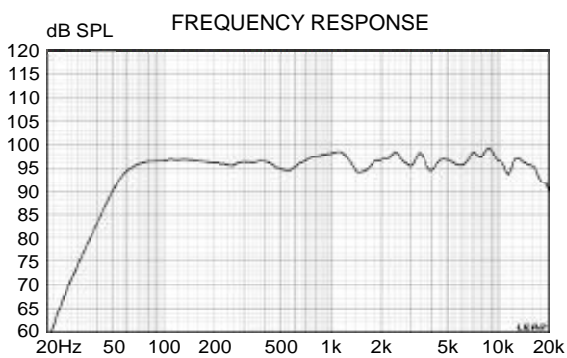
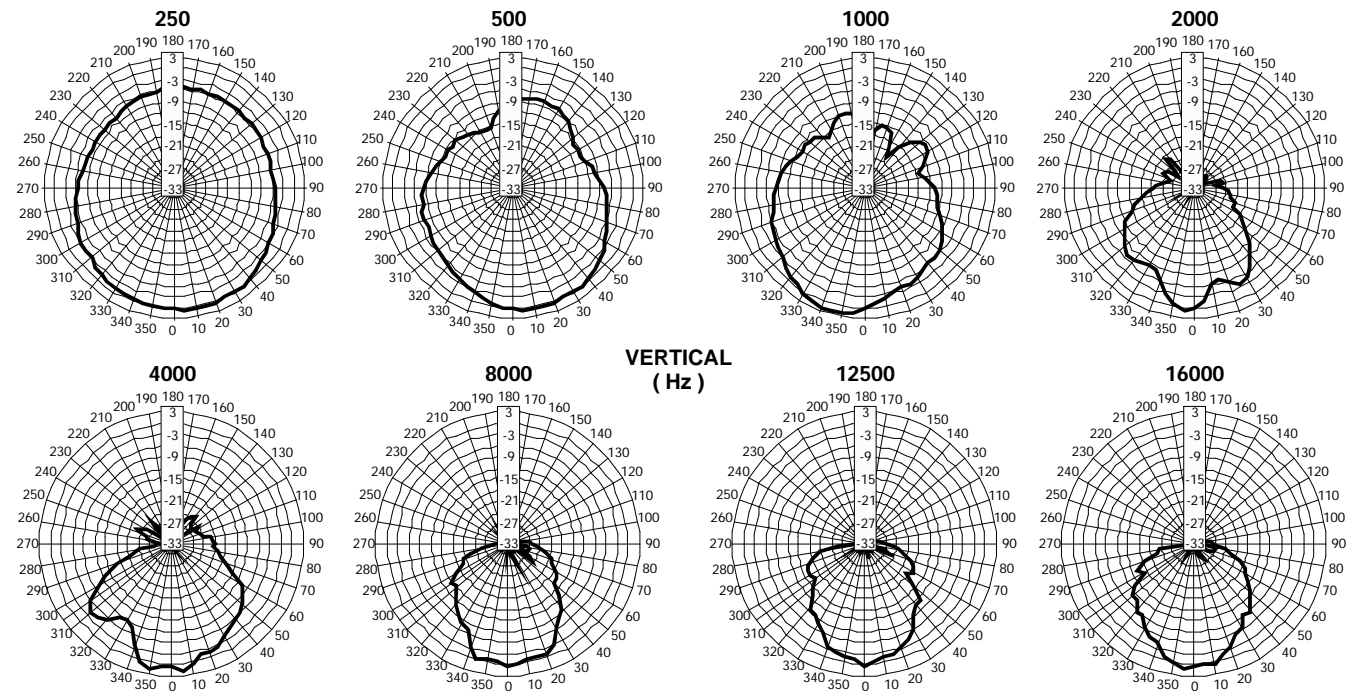
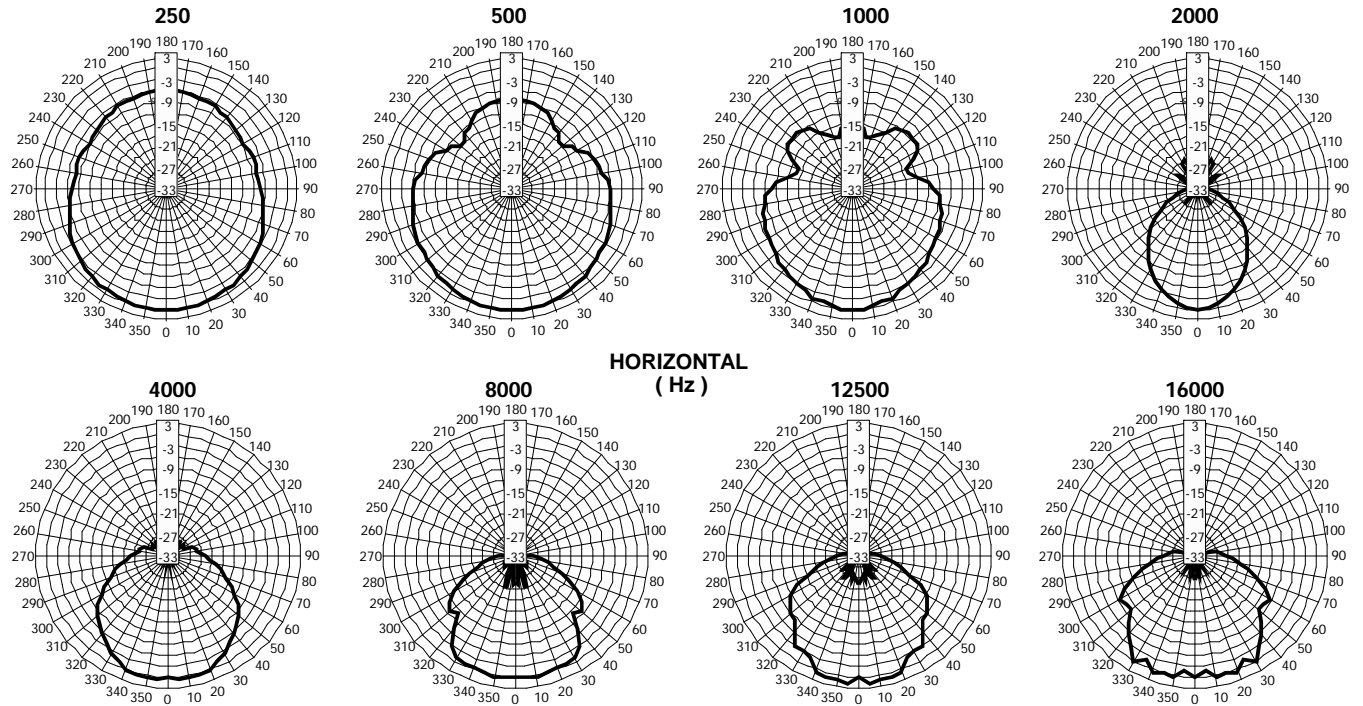

BLOCK DIAGRAM

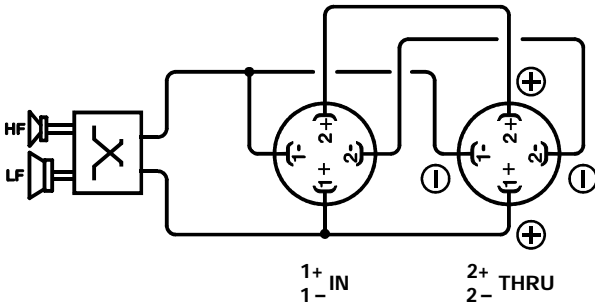

INPUT CONNECTORS

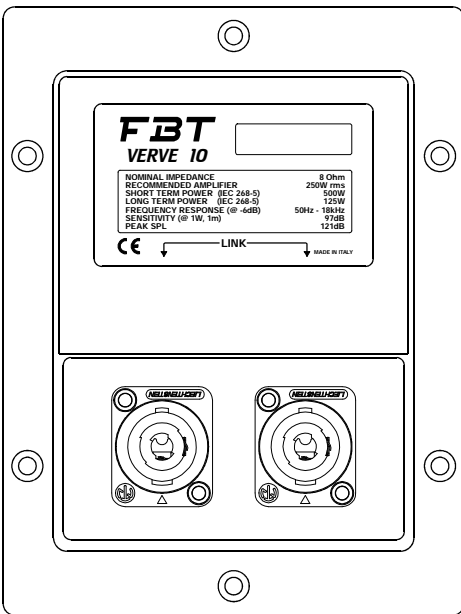

DIMENSION DRAWING

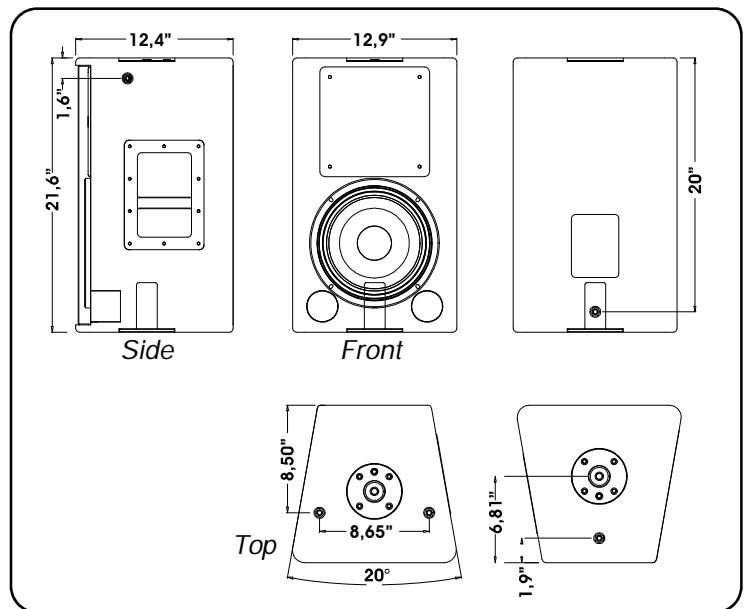

ACCESSORIES



BOX 120
Directional wall mount

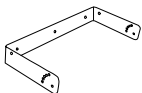

BOX 114
Mount for horizontal wall installation

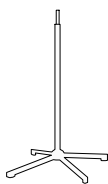

SS2
Standard speaker floor stand

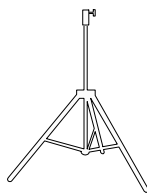

BOX 32BK
Adjustable aluminium floor stand, damped safety mechanism

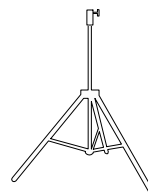

BOX 22BK
Adjustable aluminium floor stand, with $\varnothing 1''$ adapter

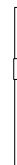

BOX 52BK
Adjustable for sub-satellite speaker connection, with safety locking device

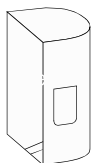

V 46
Nylon case