

FBT jolly 8b a

PROCESSED ACTIVE MONITOR

APPLICATIONS

- Houses of Worship
- School & Corporate Audio Visual Sound Reinforcement
- Background Music/Announcement: Restaurants, Pubs
- Transportation Terminals, Clubs, Auditoriums, Theatres
- Live Sound Monitoring or Small P.A. System

FEATURES

- Lightweight Polypropylene Cabinet, 18 lbs
- Bi amplified 180W RMS LF & 60W RMS HF
- 8" low frequency woofer with 1.5" voice coil
- 1" compression driver with 1" voice coil
- Control Panel with Volume control, 2 band EQ, Mic/Line switch, Ground lift switch, Balanced Neutrik combo input jack: female XLR, 1/4" TRS, Balanced Neutrik XLR link out jack, power on and Limiter led indicators
- Multiple mounting options: wall, ceiling, cluster, speaker stand, tripod microphone stand for near field monitoring use
- Two M6 fly points
- Optional Carrying Bags available for protection for portable use
- Available in black finish
- High SPL capability: 123dB
- Completely Manufactured in Italy



PRODUCT DESCRIPTION

The FBT JOLLY series speakers feature lightweight, yet rugged gas injected molded polypropylene cabinet construction. Available in a black finish the FBT JOLLY 8BA series speakers modern cabinet appearance provides fixed installations with an elegant design that blends into any decor. With the use of optional accessories the FBT JOLLY 8BA speakers can be mounted on mic stands for many near field monitor applications, live sound and as a studio monitor. The FBT JOLLY 8BA is of two-way design incorporating an 8" low frequency woofer and a 1" high frequency driver coupled to a 90°H x 60°V horn. The active internal crossover is at a fixed frequency of 2k. With a frequency range of 60Hz-20kHz the JOLLY 8BA speakers provide hi fidelity sound for both speech and music applications with a maximum SPL of 123dB. A front face steel grille protects the speaker from external damage. FBT's A.D.A.P. Advanced Dynamic Active Protection circuitry protects speaker/driver components against failure. The bi amplified FBT JOLLY 8BA active speakers feature a 180W RMS low frequency amp and a 60 W RMS high frequency amp. The control panel features a volume control, 2 band EQ with ± 15 dB of cut/boost @ 80Hz LF and ± 15 dB cut/boost @ 10kHz HF, a balanced Neutrik input combo jack, balanced XLR link output jack, microphone/line input switch, ground lift switch, led power on and limiter led indicator. The two M6 fly points built into the cabinets along with the optional mounting brackets allow the FBT JOLLY 8BA speakers to be surface mounted on walls or ceiling. For portable or fixed use the FBT JOLLY 8BA speakers can be mounted on speaker stands by using the optional adapters for vertical mounting.

ELECTRICAL PERFORMANCE

System Type:	2 Way
Internal Amplifiers*	cont.: 150W+50W RMS max.: 180W+60W RMS max. peak: 360W+120W RMS
Low Frequency Woofer	8" - 1.5" voice coil
High Frequency Driver	1" - 1" voice coil
Frequency Response @ -6dB	60Hz - 20kHz
Input Impedance	22kOhm
Maximum SPL (continuous/peak)**	117/123dB
Dispersion	90°H x 60°V
Crossover Frequency	active 2kHz
AC Power Requirement (continuous/peak)	130/360VA

PHYSICAL

Input Connectors	Balanced Neutrik Combo jack, XLR, 1/4" TRS
Net Dimensions (WxHxD)	10" x 16.3" x 9.6"
Shipping Dimensions (WxHxD)	13" x 18.9 x 12.6"
Net Weight	18 lbs
Shipping Weight	20 lbs
Enclosure Material	Polypropylene
Grille	Steel with powder coat black paint finish
Suspension Points	2 x M6
Power Supply Cable	197 inch

* CONT. : 500ms burst, rms power on nominal speaker impedance
MAX: 2ms burst, rms power on nominal speaker impedance
MAX PEAK: based on max peak output voltage and nominal speaker impedance

** CONT. SPL: free space, based on continuous power amp rating and LF transducer average sensitivity data, 125mS time average
PEAK SPL: free space, based on max. peak power amp rating and system peak sensitivity, 10mS time average

HORIZONTAL POLAR DIAGRAM (Hz)

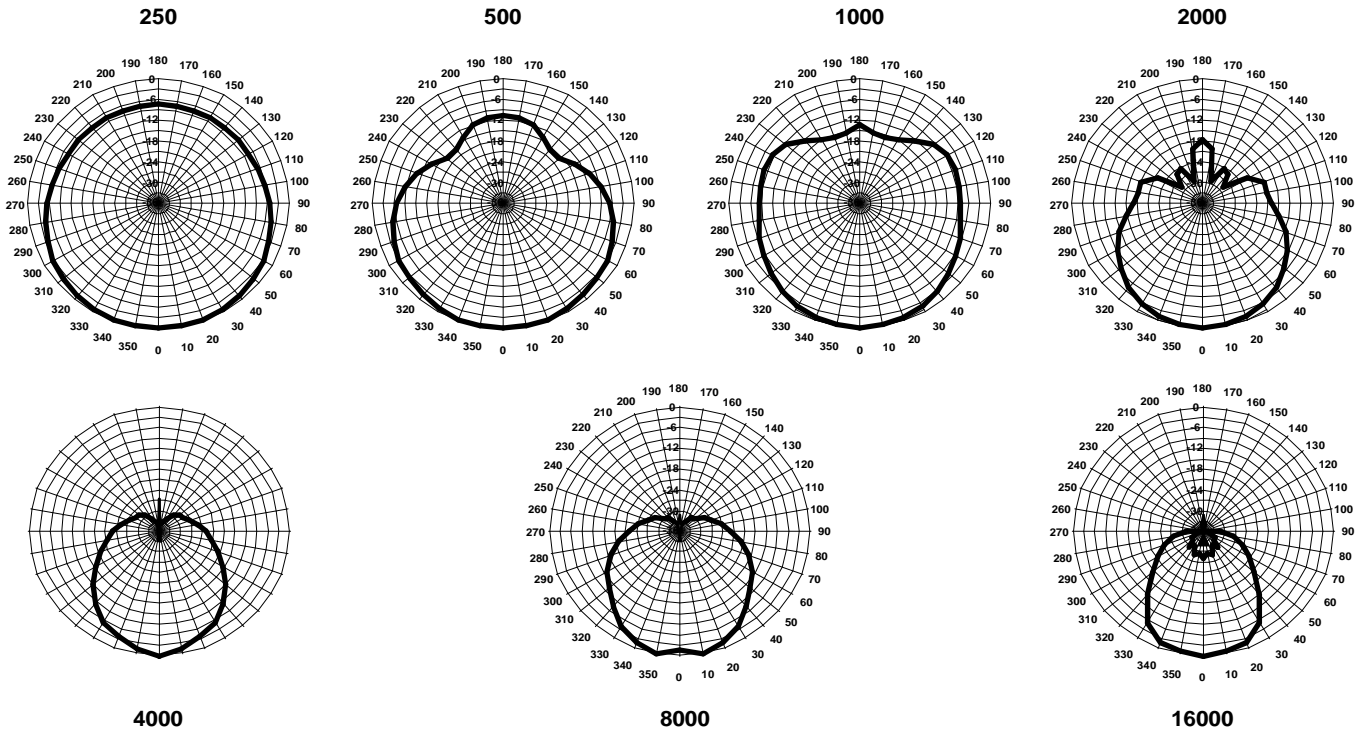

VERTICAL POLAR DIAGRAM

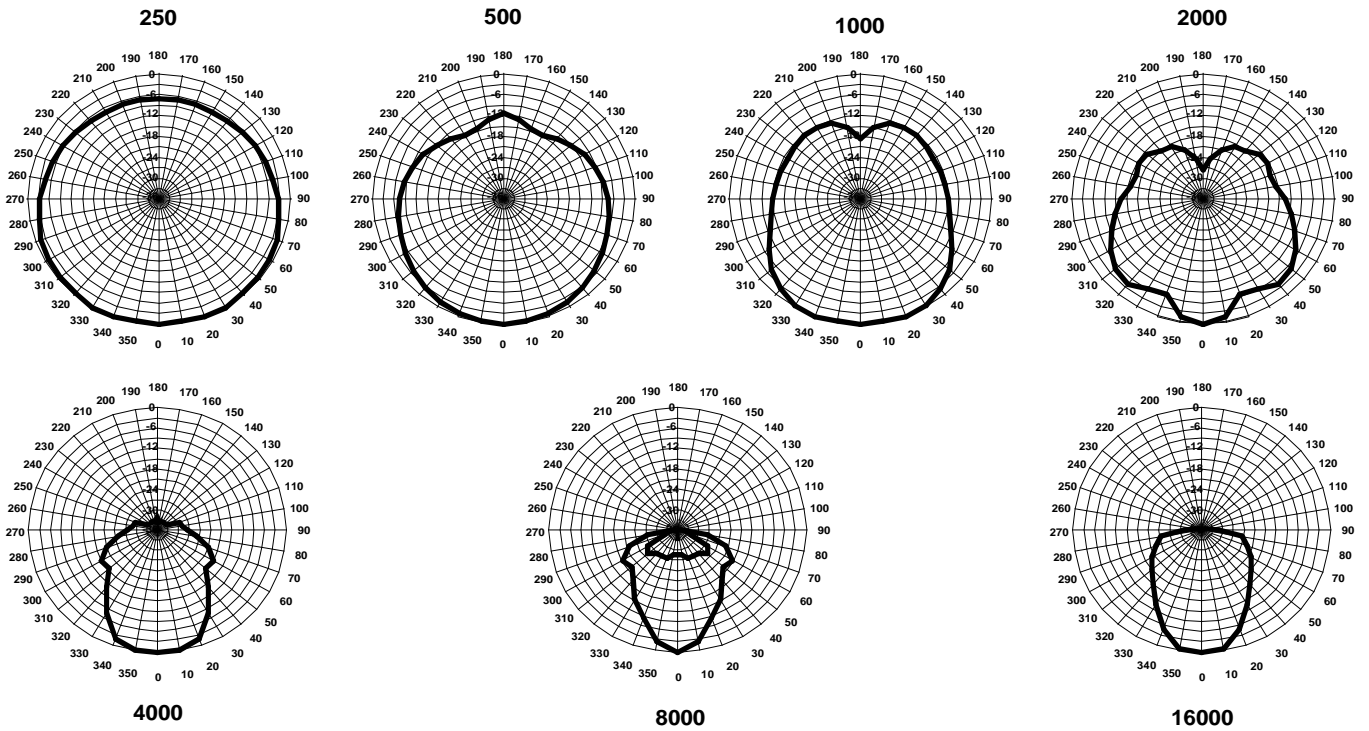

FREQUENCY RESPONSE

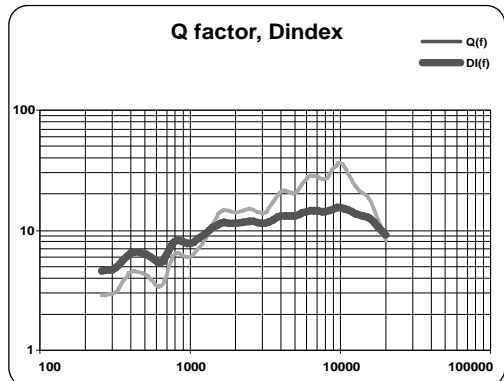
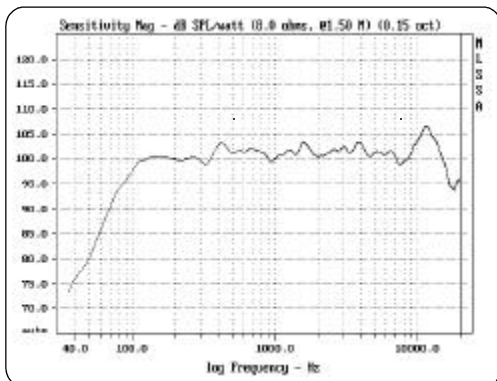

FBT jolly 8b a

PROCESSED ACTIVE MONITOR



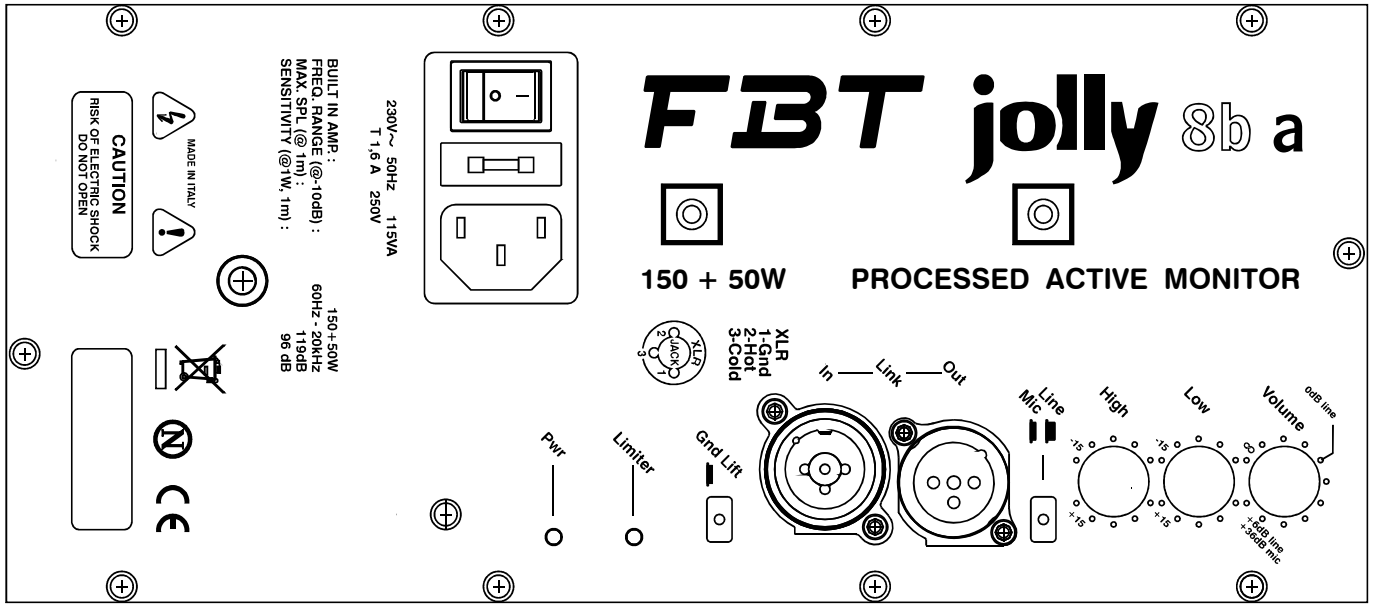

CONTROL PANEL

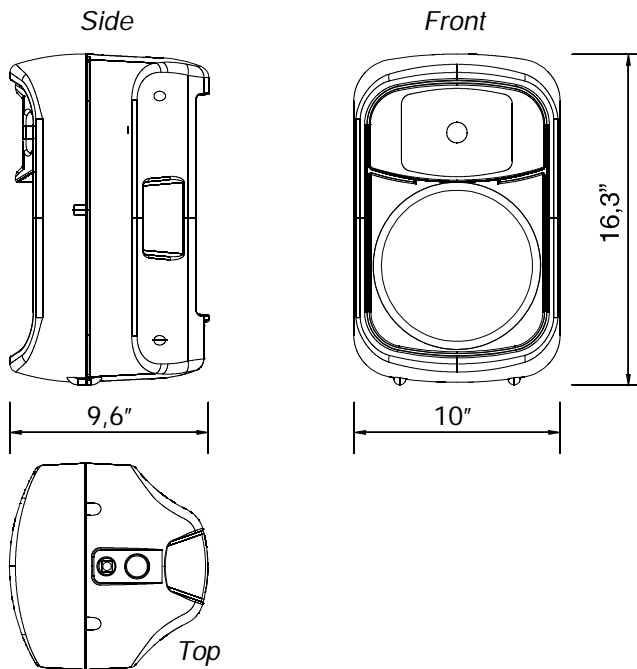

DIMENSION DRAWING

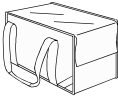
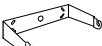

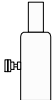
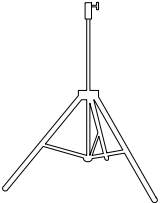
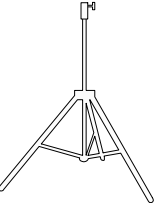
ACCESSORIES

							
V37	S/J8U	S/J8	A/J8	BOX 32BK	BOX 22BK	BOX 52BK	S/J8T
Nylon bag x 2 pcs	Mount for horizontal wall installation	Directional wall mount with ange and swivel arm	35mm (1.38") \varnothing to 25mm (1") \varnothing adapter	Adjustable aluminium oor stand, damped safety mechanism. Max weight 70 kg (154 Lb)	Adjustable aluminium oor stand \varnothing 35mm (1.38") with \varnothing 25mm (1") adapter. Max weight 40 kg (88 Lb)	Adjustable, for subsatellite speaker connection, with safety locking device \varnothing 35mm (1,38")	Adjustable T-shaped support for 2 speaker cabinets