

APPLICATIONS

- Live Sound P.A. System or Live Sound Monitor, D.J. System
- School & Corporate Audio Visual Sound Reinforcement
- Background Music/Announcement: Restaurants, Pubs
- Transportation Terminals, Clubs, Auditoriums, Theatres
- Gyms, Houses of Worship

FEATURES

- Lightweight Polypropylene Cabinet, 28,7 lbs
- Bi amplified: 260W RMS LF & 60W RMS HF
- 10" B&C custom neodymium woofer with 2" voice coil
- B&C HF compression driver with 1.4" voice coil and 1" exit
- Control Panel with Master volume control, Preamp gain control, 3 band eq, Mic/Line switch, Ground lift switch, Neutrik balanced inp/out
- Multiple mounting options: "wall, ceiling, cluster, speaker stand"
- Two M10 flypoints
- Optional Carrying Bags available for protection for portable use
- High SPL capability: 126dB
- Completely Manufactured in Italy



PRODUCT DESCRIPTION

The FBTMaxX2A active speaker feature lightweight, yet rugged gas injected molded polypropylene cabinet construction. The asymmetrical shape of the FBTMaxX 2A cabinet also allows use as a floor stage monitor. The FBTMaxX 2A is a two way design incorporating a 10" custom B&C woofer with a neodymium magnet and 1" throat B&C compression driver with 1,4" voice coil coupled to a 90°H x 60°V horn. The active internal crossover is at a fixed frequency of 1.8k. With a frequency range of 50Hz-20kHz, the FBTMaxX 2A provides hi fidelity sound for both speech and music applications with a maximum SPL of 126dB. A front face steel grille protects the woofer from external damage. FBT's ADAP (Advanced Dynamic Active Protection) circuitry protects speaker/driver components against failure. The bi amplified FBTMaxX2A active speaker features a 260W RMS Class AB low frequency amp and a 60W RMS Class AB high frequency amp. The control panel features a master volume control, preamp gain control, 3 band eq. with ± 15 dB of cut/boost @ 80Hz LF, ± 12 dB of cut/boost @ 2,5k midrange and ± 15 dB cut/boost @ 10kHz HF, a balanced Neutrik input combo jack, balanced XLR link output jack, microphone/line input switch and ground lift switch, led power on. The two M10 fly points built into the cabinet, along with the optional Box 102 mounting brackets allow the FBTMaxX 2A speakers to be surface mounted on walls or ceilings. A standard 1.38" speaker stand socket allows the FBTMaxX 2A to be mounted on speaker stands.

ELECTRICAL PERFORMANCE

System Type:	2 Way
Internal Amplifiers*	cont.: 200W+50W RMS max.: 260W+60W RMS max. peak: 520W+120W RMS
Low Frequency Woofer	1 x 10" - 2" coil
High Frequency Driver	1 x horn - 1,4" coil
Frequency Response @ -6dB	50Hz - 20kHz
Input Impedance	22kOhm
Input Sensitivity LINE/MIC	0dBu / -40dBu
Maximum SPL (continuous/peak) * *	121dB / 126dB
Dispersion	90°H x 60°V
Active Crossover Frequency	active 1,8kHz
AC Power Requirement (continuous/peak)	230/460VA

PHYSICAL

Input Connectors	Combo / XLR
Net Dimensions (WxHxD)	13,9" x 21,6" x 12,1"
Shipping Dimensions (WxHxD)	17,1" x 24,8 x 15,5"
Net Weight	28,66 lbs
Shipping Weight	34,17 lbs
Enclosure Material	Polypropylene
Grille	Steel with powder coat black paint finish
Mounting Hardware	Mounting Hardware
Power Supply Cable	197 inch

* CONT. : 500ms burst, rms power on nominal speaker impedance
 MAX: 2ms burst, rms power on nominal speaker impedance
 MAX PEAK: based on max peak output voltage and nominal speaker impedance

** CONT. SPL: free space, based on continuous power amp rating and LF transducer average sensitivity data, 125mS time average
 PEAK SPL: free space, based on max. peak power amp rating and system peak sensitivity, 10mS time average

DIAGRAMS

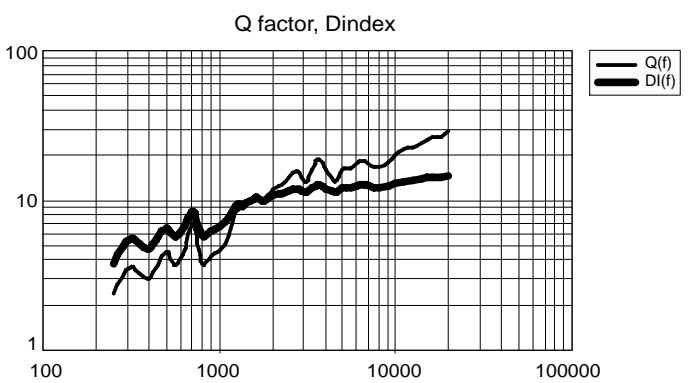
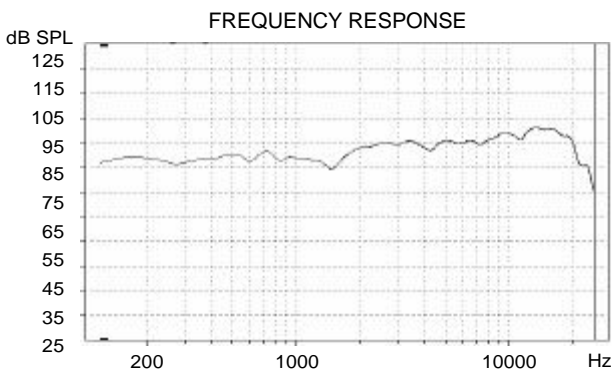
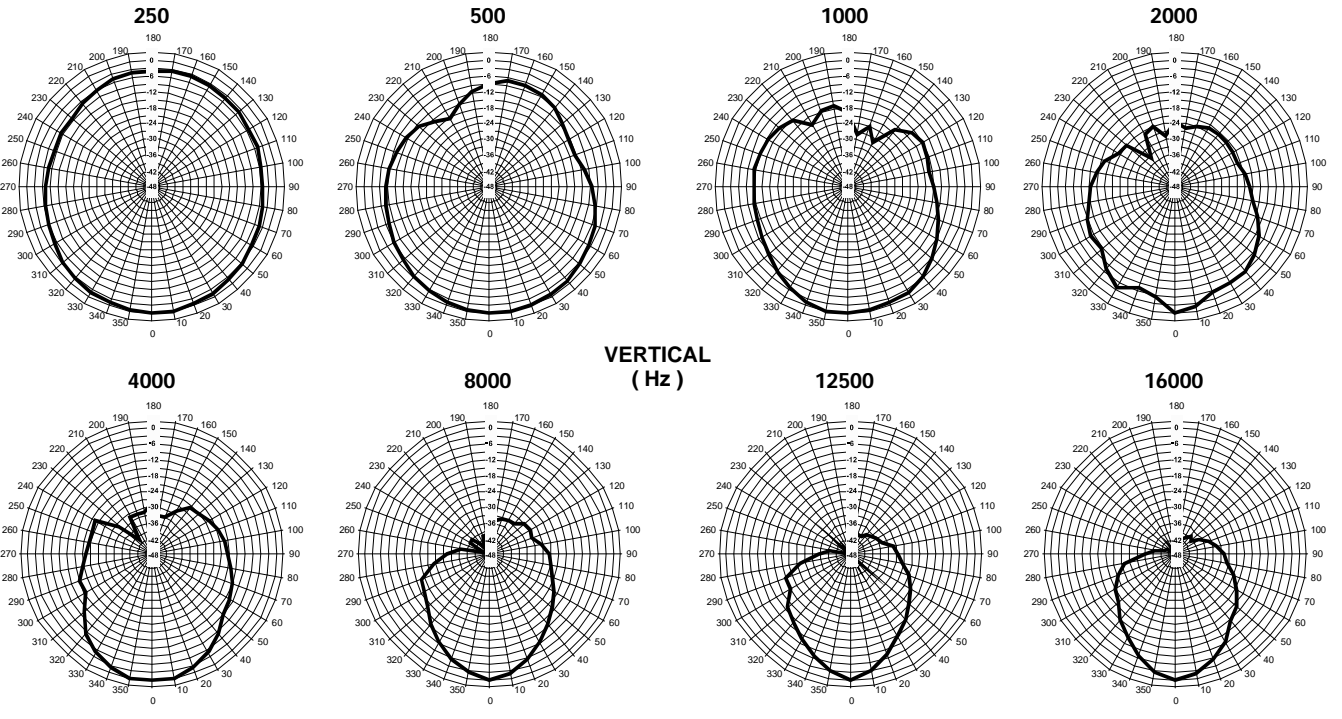
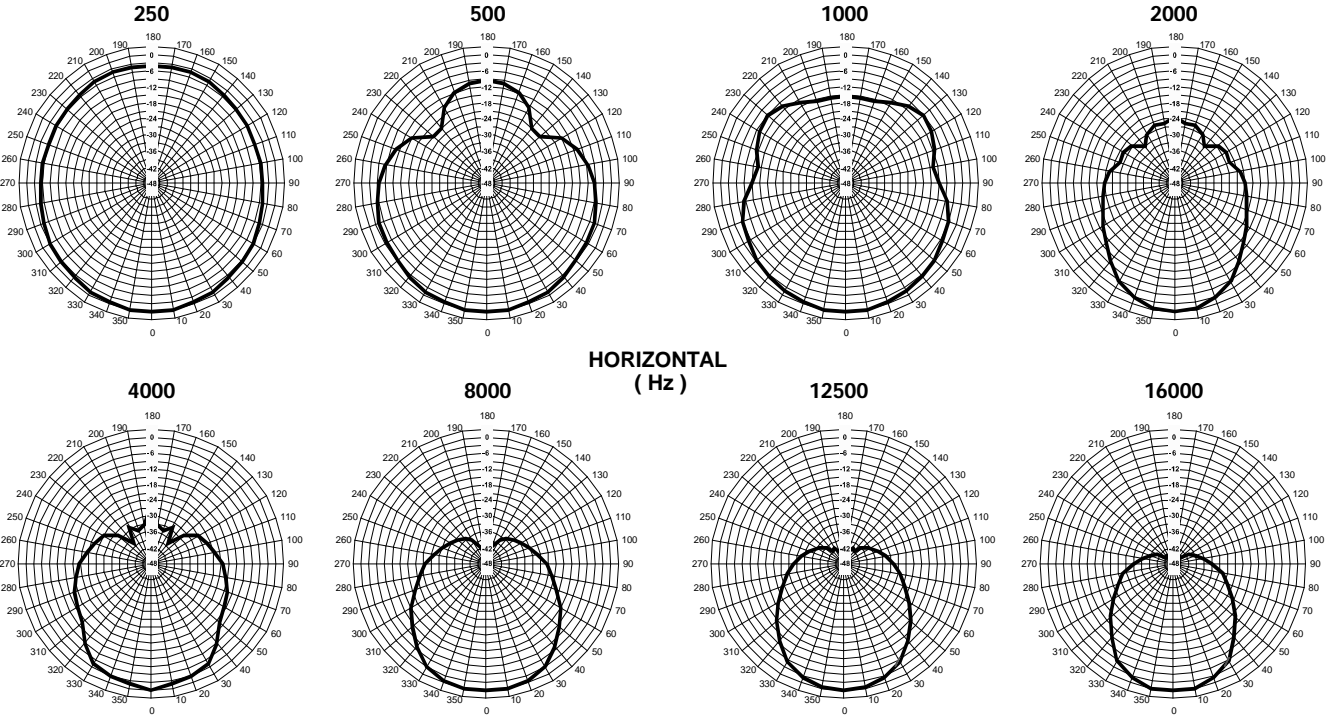

FBT

FBTMaxX 2a

PROCESSED ACTIVE MONITOR

CONTROL PANEL

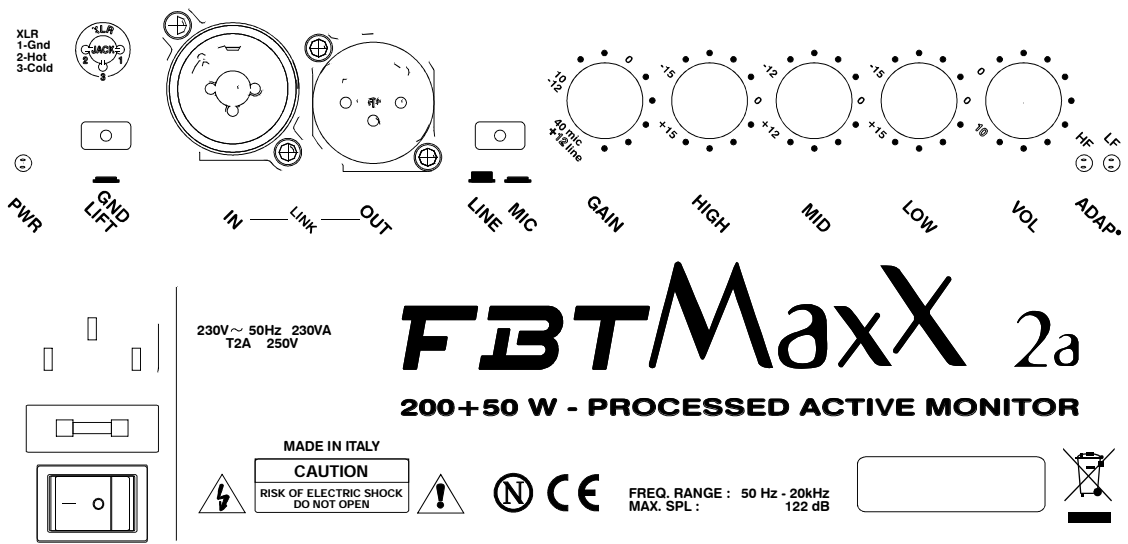

DIMENSION DRAWING

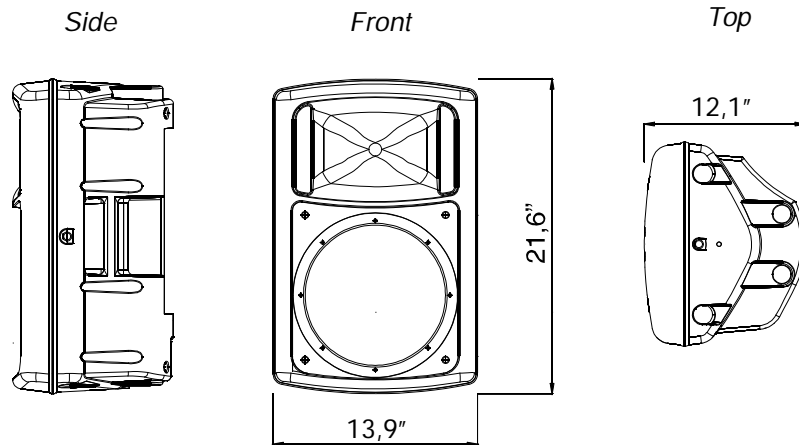

ACCESSORIES

